



European Union Network for the  
Implementation and Enforcement  
of Environmental Law

# Integrated Water Approach

---

## *Industrial Water Management guidelines*

A guidance for IED permit writers

Report number: 2017/10  
Date of report: 17 April 2018

<b>Title report:</b> Industrial Water Management guidelines	<b>Number report:</b> 2017/10
<b>Project manager:</b> Geneve Farabegoli (IT)	<b>Report adopted at IMPEL General Assembly:</b> <b>Written procedure, May 2018</b>
<b>Authors:</b> Geneve Farabegoli (IT) Francesco Andreotti (IT) Anabela Rebelo (PT) Ana Paula Malo (PT) Pinar Topkaya (TR) Alfredo Pini (IT)	<b>Number of pages: 78</b> Report: 41 Annexes: 37
Geneve Farabegoli (team leader), Francesco Andreotti, Alfredo Pini, Anabela Rebelo, Ana Paula Malo, Gabriel Dragoi, Vasile Pintilie, Pinar Topkaya, Albert Avellaneda Bargués, Darko Blinkov, Peter Šimurka	
<b>Executive summary:</b> The present Report is the result of the work of the “Integrated Water Approach” project team. It intends to be a first approach to develop a guidance document on industrial water management; consequently it is mainly addressed to IED permit writers of IMPEL and non-IMPEL states including for example the IPPC Bureau, European Environmental Agency and industry sector associations.	
<b>Disclaimer:</b> This report is the result of a project within the IMPEL network. The content does not necessarily represent the view of the national administrations.	

Suggested citation:

Farabegoli G. et al. (2018), Integrated Water Approach report. IMPEL report no 2017/10, 78 pages. Brussels, ISBN 978-2-931225-24-0

ISBN 978-2-931225-24-0



### **Introduction to IMPEL**

The European Union Network for the Implementation and Enforcement of Environmental Law (IMPEL) is an international non-profit association of the environmental authorities of the EU Member States, acceding and candidate countries of the European Union and EEA countries. The association is registered in Belgium and its legal seat is in Brussels, Belgium.

IMPEL was set up in 1992 as an informal Network of European regulators and authorities concerned with the implementation and enforcement of environmental law. The Network's objective is to create the necessary impetus in the European Community to make progress on ensuring a more effective application of environmental legislation. The core of the IMPEL activities concerns awareness raising, capacity building and exchange of information and experiences on implementation, enforcement and international enforcement collaboration as well as promoting and supporting the practicability and enforceability of European environmental legislation.

During the previous years, IMPEL has developed into a considerable, widely known organisation, being mentioned in a number of EU legislative and policy documents, e.g. the 7th Environment Action Programme and the Recommendation on Minimum Criteria for Environmental Inspections.

The expertise and experience of the participants within IMPEL make the network uniquely qualified to work on both technical and regulatory aspects of EU environmental legislation. Information on the IMPEL Network is also available through its website at [www.impel.eu](http://www.impel.eu).

# Table of contents

<b>Table of contents .....</b>	<b>4</b>
<b>Presentation of the Project .....</b>	<b>5</b>
<b>Methodology .....</b>	<b>6</b>
Phase 1 – Questionnaire diffusion.....	6
Phase 2 – First project meeting outcomes .....	7
Phase 3 – Questionnaire tuning .....	7
<b>Responses of the Questionnaires .....</b>	<b>8</b>
<b>Water management: Best Available techniques in different industrial sectors .....</b>	<b>21</b>
BREF Pulp and paper .....	21
BREF Refining of Mineral Oil and Gas .....	22
<b>Principles, requirements, drivers and barriers in industrial water management .....</b>	<b>23</b>
Principles .....	23
Requirements .....	24
Drivers .....	26
Barriers .....	28
<b>IED requirements compared to WFD requirements for Industrial Water Management.....</b>	<b>30</b>
<b>Check list and suggestions for IED permit writers.....</b>	<b>35</b>
<b>Conclusions and Recommendations .....</b>	<b>39</b>
<b>ANNEXES.....</b>	<b>42</b>
Annex 1 – ToR .....	43
Annex 2 – QUESTIONNAIRES SCHEME.....	50
Annex 3 – CASE STUDIES .....	64

## Presentation of the Project

The implementation of EU legislation on water and land has been identified as one of the top challenges in recent IMPEL research because difficulties at several levels such as the transposition of EU legislation into national laws as well as the setting of environmental objectives and plans in Member States and the enforcement of the requirements, for example through permitting and inspection regimes.

In this framework, recently, the IMPEL-project “Integrated water approach” (IWA) took off.

Integrated water approach is a one-year project that has the following aims:

- 1) to collect and compare the procedures that are used within Europe for water resources management and protection in the industry sector;
- 2) to identify new approaches for reducing fresh water consumption and innovative technologies for industrial water treatment able to provide energy saving, sludge production minimization and water reuse for multiple purposes;
- 3) to use this information for developing a guidance document to share among IMPEL members and other non-IMPEL participants including for example the IPPC Bureau, European Environmental Agency and industry sector associations.

A survey has been used to collect the information on water management in industry within EU. This survey has been carried out by means of questionnaires filled in by people that are responsible or involved in environmental permitting, monitoring, compliance promotion and assessment, enforcement action, industry sector associations etc..

From the responses obtained by the survey we have identified principles, requirements, drivers and barriers in the industrial water management sector and selected several case studies/experiences.

We have compared the IED requirements to WFD requirements for industrial water management and through the development of this guidance document we try to provide a check list and suggestions for IED permit writers.

# Methodology

## *Phase 1 – Questionnaire diffusion*

On February 2017 we prepared a survey made by the use of a questionnaire distributed among the IMPEL members.

We selected a list of authorities and individuals across EU involved in environmental permitting, compliance, assessment, enforcement as well as industry sector associations to send them the questionnaire.

As an example the following organizations have been considered:

- State Level Competent Authority for IED application (Ministry of Environment);
- State Level Competent Authority for IED application in farming (Ministry of Agriculture);
- Regional Level Competent Authorities for IED application;
- National association representing the manufacturing and service companies;
- Federation of water and environmental companies of public service;
- National association representing the oil companies;
- National association representing the pulp and paper industry.

We diffused the questionnaire structured as follows.

The questions in the questionnaire have been divided in 6 different sections:

- Section A – General information
- Section B – Regulation
- Section C – Plant operational characteristics
- Section D – Water usage
  - Water source
  - Water reuse
- Section E – Wastewater treatment
- Section F – Wastewater discharge

In section A we asked to introduce the type of organization responding the questionnaire. In section B we asked to describe how the EU legislation on water resources management and protection has been implemented in the industry sector, in that specific country. In section C we asked more about the plant operational characteristics. In section D (water supply and reuse), E (generated wastewater treatments) and F (effluent discharge) we referred to a real installation that could be considered as an example for best practices. Anyway, if there were several examples of homogeneous installations adopting same techniques of water management, the description could not necessarily be related to a real installation, but it could be representing the average values of installations having the same characteristics.

## ***Phase 2 – First project meeting outcomes***

The questionnaire was disseminated among several stakeholders and the responses were analyzed to summarize main findings.

The first project working group meeting was held in Rome at the beginning of May 2017.

During the project meeting the working group agreed:

- to focus the project and the IWA GLs on three industrial sectors, subject to the Industrial Emission Directive (IED), that represent significant environmental issues for water consumption and discharge as well as for water reuse needs: refinery, pulp&paper, textile;
- that the IWA GLs should be addressed, in particular, to permit writers in order to set priorities for the permitting system when water management issues could be of major importance;
- that the questionnaire is the fundamental methodology tool that plays a key role to collect the information needed to develop the IWA GL;
- that the IWA GL should also include a check list for each selected industrial sector, in order to specifically address the main water management issues such as water supply, water consumption, water saving, water reuse, wastewater treatment, etc., and suggest priorities to permit writers;
- to redistribute the questionnaire and to request it to be filled in with information, data and descriptions preferably at “case study” level related to the three selected sectors.

## ***Phase 3 – Questionnaire tuning***

We diffused again the questionnaire structured as previously mentioned.

The questions in the questionnaire were always divided in the same 6 different sections. This time we asked to fill in the questionnaire considering that:

- sections B and C attain to regulation as well as industry sectors description and here there should be an overview of the legislation that regulates the field of interest (a geographical area for a competent authority, and industrial sector for an operator or for a industry firm); sections B and C are basically thought for competent authorities or land planning authorities;
- some of the section B and the whole section C questions could be not applicable if a specific case study has been described.
- if an individual provides a case study (hopefully in the refineries, pulp&paper or textile sector) they are supposed to fill the following sections: A, B1a or B1b, B3, B5, the whole section D and E where applicable, F2 and F3;
- a representative of an authority should be able to answer all the questions.

# Responses of the Questionnaires

In some cases the organizations did not have all the information requested or it was not easy to obtain it because of the considerable commitment of time. Anyway we could summarize the main findings as described as follows.

## Section A – General information

During the Phase 1 we received 10 questionnaires from 7 different countries:

- # 3 from Portugal: PT1- the Portuguese Environment Agency, PT2 – a Regional direction of the ordinance of the territory, PT3 – a Paper industry association;
- # 1 from Slovakia: SK – the Slovak Environmental Inspectorate;
- # 1 from Italy: IT – an Italian Refinery;
- # 1 from Spain: ES – the Ministry of Territory and Sustainability;
- # 2 from Turkey: TR1, TR2 – the Ministry of Environment and Urbanisation;
- # 1 from the former Yugoslav Republic of Macedonia: MK – the Ministry of Environment and Physical Planning;
- # 1 from United Kingdom: UK- the Environment Agency.

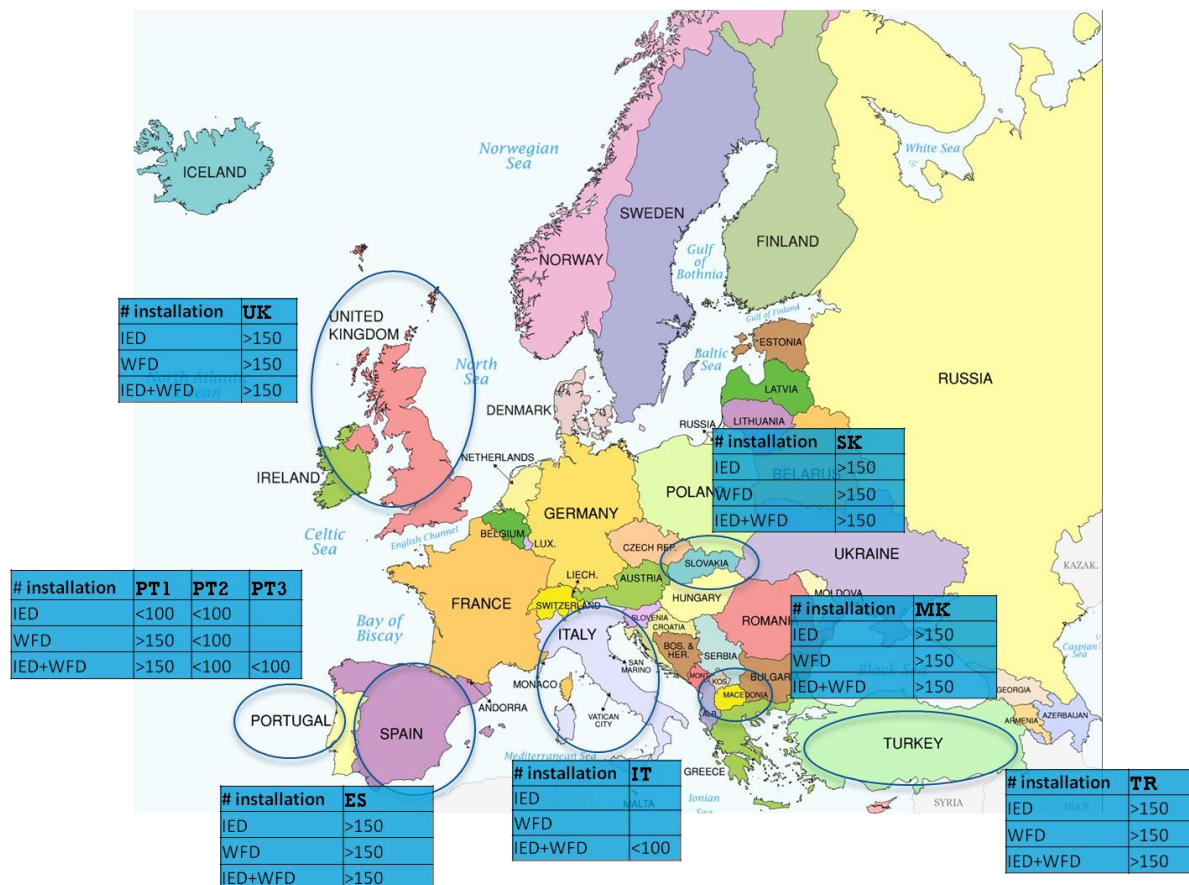

Fig 1



During the Phase 3 we received 14 questionnaires from 7 different countries:

# 3 from Germany: DE1 - the Authority for industry approval, DE2 - the Department for Occupational Safety and Environment of a Regional authority, DE3 - the State Agency for Agriculture, Environment and Rural Areas of a German Federal State;

# 3 from Italy: IT - an Italian Refinery, IT2 - a Public owned Company treating industrial effluent from tanneries, IT3 - the Association pulp and paper industry;

# 3 from Romania: RO1 - the National Administration Romanian Waters, RO2 - a Refining & marketing Industry, RO3 - a Pulp and Paper industry;

# 2 from Portugal: PT3 - a Paper industry association; PT4 - a Refining & marketing Industry,

# 1 from Slovakia: SK2 - the Authorizing and Inspection Authority;

# 1 from Latvia: LV- the State Environment Service Madonas Regional Environmental board;

# 1 from Cyprus: CY - the Department of Environment, Ministry of Agriculture, Rural Resources and Environment.

Among the 14 questionnaires 3 are relative to the Refinery sector and 3 to the Pulp and Paper sector. We received only 1 questionnaire coming from a company treating industrial effluent from tanneries and 0 from the textile sector.

**Consequently we decided to focus this GL only for the refinery and the pulp&paper sectors.**

## Section B – Regulation

### IED Enforcement

PT1	PT2	PT3	SK	IT
Portuguese Environmental Agency <b>licenses the water resources uses</b> , including water abstraction and wastewater discharges (industrial emissions) in addition to the <b>environmental licensing</b> carried out by the Department of Environmental Licensing	The Regional direction of the ordinance of the territory and environment is the <b>competent authority</b> in Madeira for the IED implementation and enforcement	Paper industry associated companies are <b>all under IED</b> and the respective compliance is mandatory	Unit IPPC of Slovak Environmental Inspectorate is the <b>permit and control authority</b>	The refining sector <b>has to comply</b> with the obligations/prescriptions arising from Italian environmental law code

ES	TR	MK	UK
The <b>competent authority</b> is the Directorate-General for Environmental Quality and Climate Change of the Government of Catalonia (DGQACC)	<b><u>IED is not transposed to national legislation yet.</u></b> Ministry of Environment and Urbanisation is responsible for transposition of this directive. Industrial activities are permitted and inspected <b>according to the national legislation.</b> Ministry and provincial directorates are responsible for permitting and inspections.	<b><u>In process of preparing for full transposition on IED</u></b>	Environment Agency is the <b>Competent Authority</b> for implementing IED and reviews all permits to ensure the requirements of IED are met, in particular that the BAT Conclusions are complied with within the 4 year window, post BREF review as required by IED.

IT2	IT3	PT4
Disposal of non-hazardous waste with a capacity exceeding 50 tonnes per day involving biological treatment. Landfill receiving more than 10 tonnes of waste per day or with a total capacity exceeding 25000 tonnes.	The association participated at the discussion on the IED directive, took part at the Sevilla Process for the Pulp and Paper BREF and now is helping the Italian paper mills in the renewal of the Environmental Integrated Permit (AIA).	The refining complex comprises two refineries which, together, have currently a crude processing capacity of 330,000 barrels a day. Both refineries are under IED (activities listed in Annex I of the IED).

## WFD Enforcement

PT1	PT2	PT3	SK	IT
Portuguese Environment Agency <b>elaborates the River Basin Management Plan</b> such as the one for Algarve's River Basins (RH8)	The Regional direction of the ordinance of the territory is the <b>competent authority</b> in Madeira for the WFD implementation and enforcement	Paper industry associated companies <b>have permits for water abstraction, wastewater discharge</b> , namely industrial wastewater	Unit water protection of Slovak Environmental Inspectorate is the <b>control authority</b>	The refining sector <b>has to comply</b> with the obligations/prescriptions arising from Italian environmental law code

ES	TR	MK	UK
Catalan Water Agency (ACA) is the <b>competent authority</b>	WFD <b>is not transposed to national legislation yet</b> . Ministry of Forestry and Water Affairs is responsible for transposition of this directive.	<b>Ministry of Environment and Physical Planning is responsible for the transposition and implementation of WFD</b>	Environment Agency is the <b>Competent Authority</b> for WFD, establishing River Basin Management plans to set out and then help achieve compliance with WFD at a catchment level

IT2	IT3	PT4
1. abstraction, impoundment, storage, treatment and distribution of surface water or groundwater 2. waste-water collection and treatment facilities which subsequently discharge into surface water.	No direct involvement	The refining complex manages its environmental impacts, including risk and opportunities regarding water/wastewater management. Certain activities are obliged to comply with water/wastewater requirements.

## EU legislation implementation

PT1	PT2	SK	IT
<b>Environmental legislation and water management are guaranteed by the Portuguese Environmental Agency</b>	<b>The enforcement is achieved through the assessment of the environmental reports presented by the operators and by periodically site-inspections</b>	EID Direction = law 39/2013 Z.z. WFD Direction = law 364/2004 Z.z.	Responsible for policy making and environmental permitting is the <b>Environmental Ministry</b> . Responsible for inspection is <b>ISPRA</b> Responsible for enforcement is each Refinery <b>site manager</b>

ES	TR	MK	UK
<u>Installations under IED</u> : prescriptions related to water resources management, emission limit values, monitoring and enforcement issues  <u>Installations not under IED</u> : have to get a water discharge permit <b>granted by Catalan Water Agency</b> (in case of direct discharge) or by <b>local authorities</b> (in case of discharge to a public waste water treatment facility)	Two ministries (MoEU and MFWA) have a role in <b>water resources management and protection</b> according to the national legislation	<b>For issuing a water permit is responsible Ministry of Environment and Physical Planning-Water department, for inspection State Environmental Inspectorate and Authorized Environmental Inspectors from municipalities</b>	Within England, the <b>Environment Agency is responsible for permitting, inspection and enforcement</b>  Within the UK, Defra (Government Department for Environment, Food & Rural Affairs) <b>is responsible for policy making</b>

**PT1**

The Portuguese Environment Agency (APA) is accountable for proposing, developing and monitoring the implementation of water resources policy. APA'S responsibilities: ensure protection and valorization of water resources, through planning and resources management (water use), river basin districts management, issuing the use of water resources permits and monitoring its compliance, the analysis of the characteristics of each river basin district and the impact of human activities, the economic analysis of water uses, implementation of the economic and financial regime in river basin districts, management of monitoring networks, development of a strategy for the protection and integrated management of the coastline, as well as ensuring the achievement of the objectives of the Portuguese Water Law.

Compliance to EU legislation

PT1	PT2	SK	IT
Licensing, Monitoring, government oversight, intersectorial/interministerial co-working	In the environmental permit are established <b>emission limit values</b> to be applied to the treated wastewaters and the <b>respective conditions for the self-monitoring</b> according the law for water resources management	Installations are set terms with EU legislation	By the environmental integrated permit (IED + WFD). <b>Every year the competent authority imposes an environmental survey</b> per each Refinery in order to assess the compliance review

ES	TR	UK
They are submitted to an <b>inspection or control system</b>	State Hydraulic Works is responsible for managing water resources and abstraction permits and inspections. <b>MoEU is responsible for approval of projects</b> for wastewater treatment plants and deep sea discharge. <b>MoEU and PDEU are responsible for granting environmental permits</b> to the installations which have a discharge to the receiving environment. MoEU and PDEU are responsible for <b>inspecting</b> these installations. The intervals for internal monitoring for wastewater discharge is determined in the legislation. Some of these <b>samples</b> are taken by the inspectors from PDEU. According to the Environmental Law, MoEU and PDEU have to apply <b>sanctions when non-compliance is found</b> . Administrative fines can be imposed or an order to stop the activities of the site can be given	Environment Agency both <b>write and enforce the IED permits</b> via a national permitting approach that ensures consistent permits are delivered to Operators. <b>Enforcement</b> is carried out by <b>local Area teams</b> based on river catchment/ County boundaries with oversight by <b>national Sector groups</b> to help ensure consistency

**PT4**

It is ensured through: EU legislation transposal to national law; permits and water resources use authorization issued by APA; periodically monitoring and performance report disclosure to APA; the Company's internal and external audits.

Permitting process system

PT1	PT2	SK	IT
Website for license of any kind of water use (abstraction, retention, occupying, rejection, etc..) <b>SILiAmb</b> ( <a href="https://siliamb.apambiente.pt/">https://siliamb.apambiente.pt/</a> ) developed by the Government	The environmental process follows the principles related with industrial emissions and the rules to avoid or reduce the emissions to air, water and soils and to minimize the waste production to ensure a high level of environmental protection	<b>1. EIA 2. Land permit 3. IED – IPPC permit 4. Approval permit</b>	The permitting process derives directly <b>from IED+WFD scheme</b> of adoption

TR	MK	UK
<p>The permitting process is a <b>two-step procedure</b>:</p> <p>1. The temporary operation certificate (TOC) is considered a pre-permit for the facility. <b>The TOC is valid for 1 year</b> but a company which has been granted a TOC must prepare all emission documents and provide these to the ministry <b>for review in 6 months</b></p> <p>2. Once the necessary documentation is in place the company can collect and submit the information to the ministry which has <b>60 days to evaluate the documents</b>. If the company is compliant they are issued a <b>permit which is valid for five years</b>. They can then prepare their application for renewal. BAT's are not assessed during permitting</p>	<p>The use of waters from surface and ground water bodies is subject to a water use permit.  <b>MoEPP is the designated responsible authority for issuing all water use permits</b></p>	<p>Applicants look at our forms and guidance <b>on line and submit an application to our permitting support centre</b>. The application is reviewed to ensure it is correct and we are able to process it.</p>

## PT1

The permitting process follows the Portuguese laws: Law n.º 58/2005, 29/12 with the Law-Decree n.º 226-A/2007, 31/12. Permitting request can be made online by filling out an application form.

Section C – Plant operational characteristics

Categories of activities:

- ✓ *EI – Energy industries*
- ✓ *PM – Production and processing of metals*
- ✓ *MI – Mineral industry*
- ✓ *CI – Chemical industry*
- ✓ *WM – Waste management*

- ✓ *Other activities:*
  - Tourism, agricultural industry, fishing, aquacultures
  - Food and drinks
  - Pulp and paper
  - Surface treatments
  - Textiles
  - Rearing

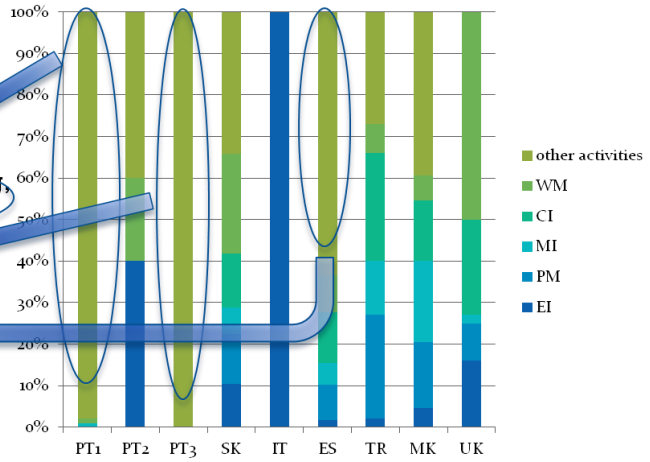

Fig.2

Installations relevant in terms of water usage:

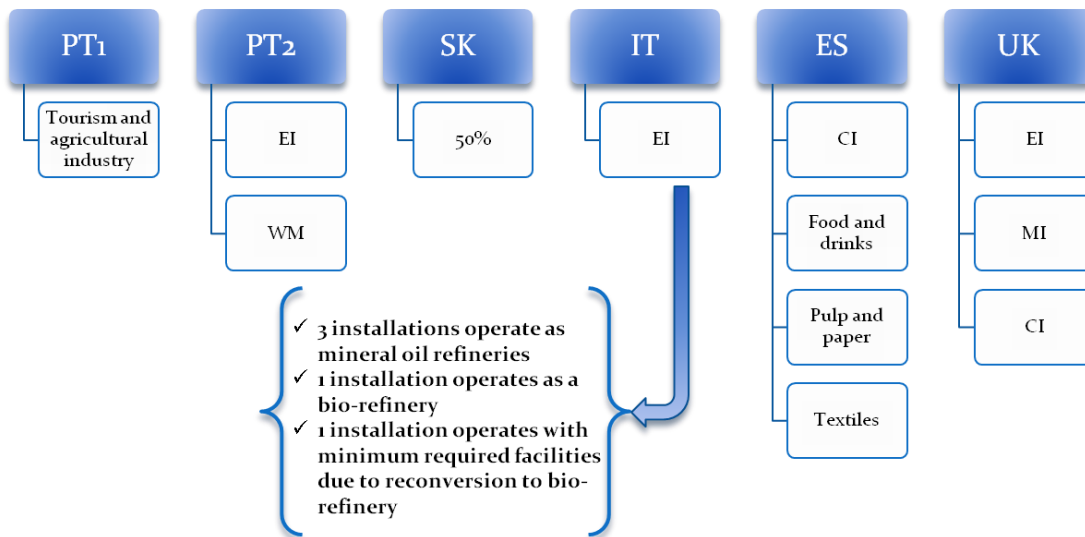

Fig. 3

Installations relevant in terms of water reuse and saving:

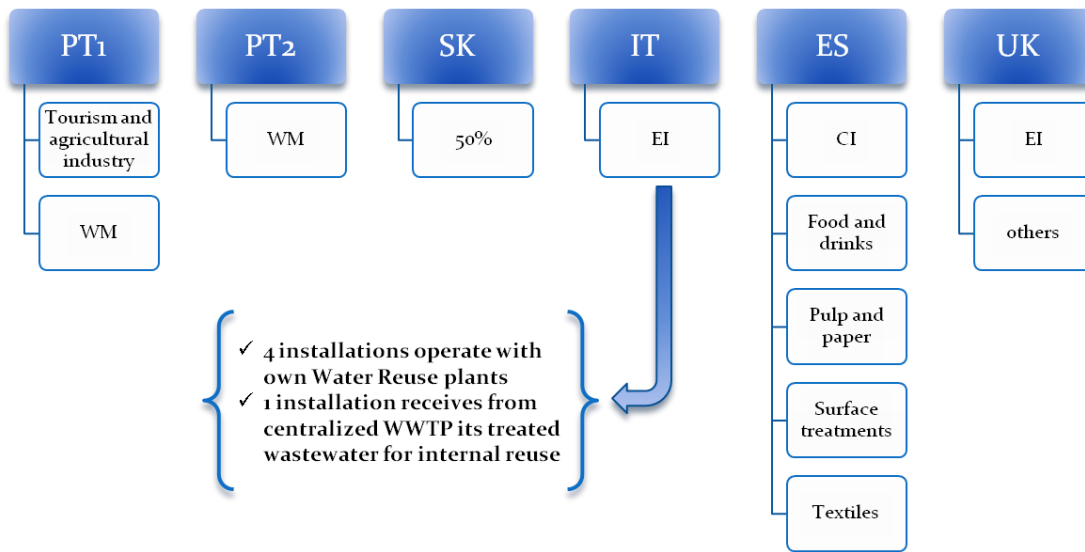

Fig. 4

Installations relevant in terms of wastewater discharge:

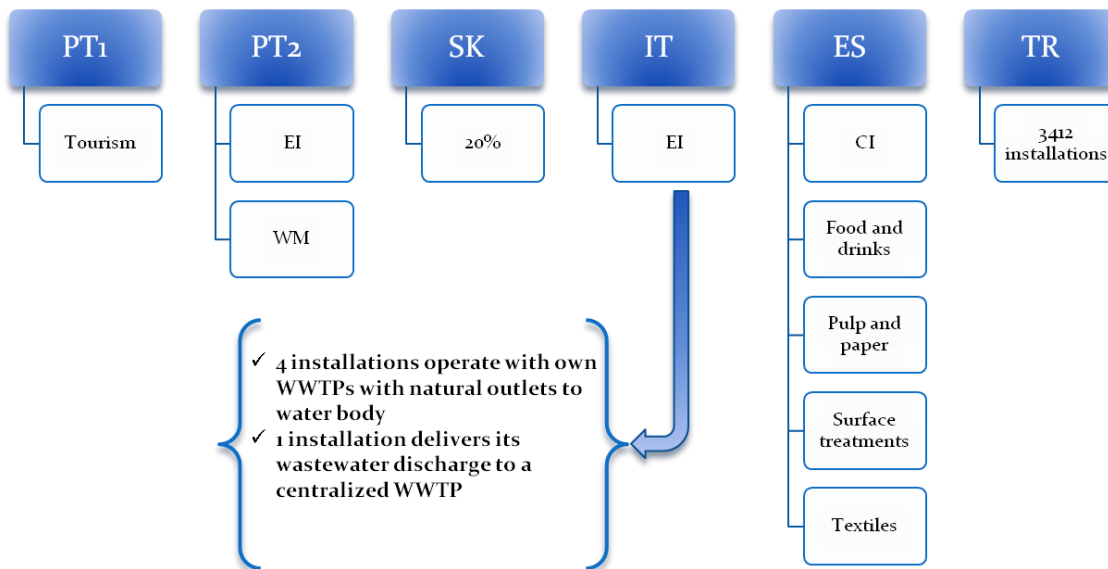
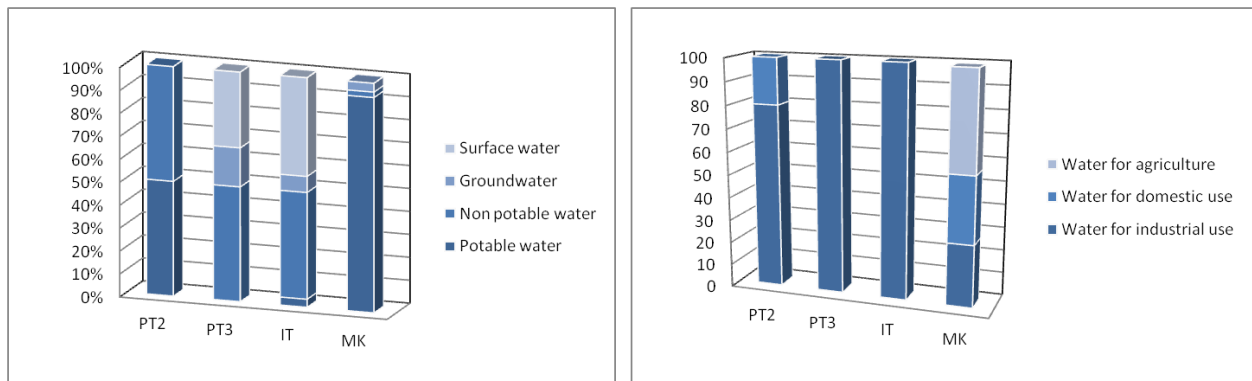

Fig. 5

## Section D – Water usage

### Water supply & use:



	PT2	PT3	IT	MK
Average water supplied	55.000 m <sup>3</sup> /year	100.000.000 m <sup>3</sup> /year (13 companies)	10.400.000 m <sup>3</sup> /year (based on water usage of 5 refineries)	581,8 million m <sup>3</sup>

Fig. 6

	PT2	PT3	IT	MK
<b>Raw water treatment process in use and manufacturing process treated water is used for</b>	Raw water is treated by <b>physical-chemical treatment and reverse osmosis</b> treatment facility which allow the reuse of wastewater from the WWTP as process water in the other ETRS facilities, Incineration of Urban Solid Waste (IIRSU) and irrigation of landscape.		Industrial raw water is collected to physical-chemical treatment step to produce process water and boiling feed water. <b>Ion exchange resins, ultrafiltration and reverse osmosis techniques</b> are used for water reuse and boiling feed water make-up	In the period 2009-2013 fresh water for technical purposes was used the most (approximately 99%). In 2013, out of a total of 2438 mil. m <sup>3</sup> of used fresh water in industry and mining, 2101 mil. m <sup>3</sup> were industrial water and 324 mil. m <sup>3</sup> fresh drinking water
<b>New approaches for reducing fresh water consumption</b>	The Solid Waste Treatment Station (ETRS) is equipped with a set of systems that allow the recovery and reuse of the waters used. In particular, the use of water in the process itself, the use of closed systems in the production of steam and the cooling of equipment. The remaining waters are sent to the WWTP where after treatment by <b>Reverse Osmosis</b> treated water is reused again in the incineration process as process water and in the production of demineralized water to the water-vapor circuit.	yes	<b>Water reuse plants</b>	By permitting use, where the holder of the license granted to capture water from the water body exclusively the needs of the place and while respecting the norm. Also the system of water rates
<b>Measure adopted for minimizing water losses</b>		In the last 10 years, the same amount of pulp is produced with less 6 m <sup>3</sup> of water which means a <b>reduction of 23% in the water consumption</b> . This results from investments to optimize the water use in each phase of the industrial process.	<b>Recovered water by means of steam condensation from pipes/equipment</b>	

Water reuse:

PT2	IT
1. All excess industrial waste water, together with the leachate and domestic wastewater is treated at the WWTP and then essentially reused in IIRSU.	1. Sand filters 2. Granular active carbons 3. Ion exchange resins 4. Ultrafiltration 5. Reverse osmosis

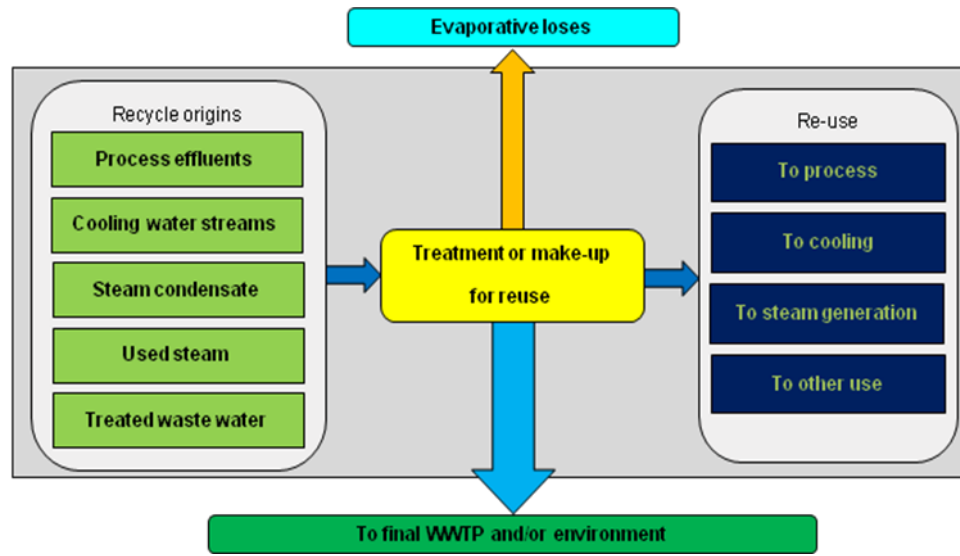

Fig. 7

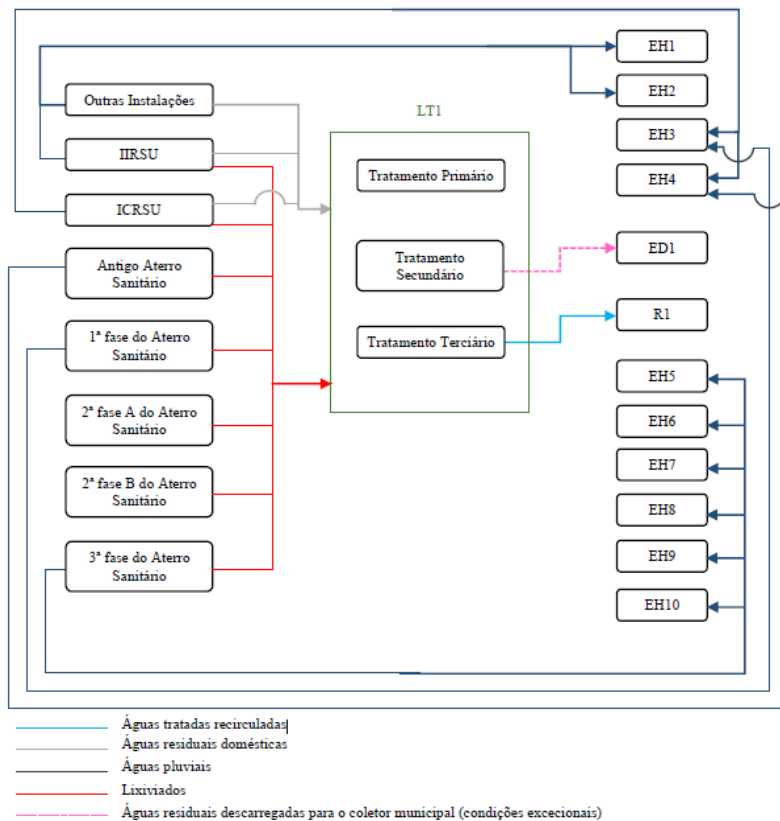

Fig. 8

The partial reuse in the same industry is 100 %



Technologies for water reuse processes:

	PT2	SK	IT	MK
Bio-oxidation and bio-treatment (anaerobic, aerobic, nitrification, other)	x	x	x	
Carbon treatment (sorption or adsorption)		x	x	x
Centrifuge (non-gravity separation)		x		x
Chemical oxidation (ozone, wet air, peroxide, super- critical, other)		x		
Chemical treatment (chlorination, conversion, other)		x		x
Crystallization		x		
Electrodialysis		x		
Evaporation (mechanical, ponds, distillation)		x		
Filtration (granular bed, vacuum drum, press, belt filter, other)		x	x	x
Flotation		x		
Gravity separation or settling (coagulation, flocculation or clarification)	x	x	x	x
Ion exchange		x	x	
Membrane separation (reverse osmosis, ultrafiltration)	x	x	x	
Precipitation		x		x
Solidification or stabilization		x		
Solvent extraction		x		
Stripping (steam, air, other)		x		
Thermal treatment (drying, incineration, spray drying, other)		x		
Other		x		

Selection of technologies is mainly due to Process Performance / Meets Requirements & Cost.

Motivation for water reuse:

	PT2	SK	IT	MK
<b>Cost Savings</b>	x	x		x
<b>Corporate Policy</b>		x	x	
<b>Community Action</b>		x		
<b>Restricted Water Supply</b>		x	x	x
<b>Other: Groundwater remediation to be treated and reused inside the refinery</b>			x	

	PT2	IT
<b>Have process analysis, water balance and utilities optimization to enhance water reuse been done ?</b>	The IIRSU project, as well as the other ETRS facilities, included the analysis of the inherent processes for the reuse of waters produced in the station, in order to increase the availability of water and the reduction of costs	Water mass balance has always been done either to enhance water reuse or to comply with emission limit value before discharge to water body

Section E – Wastewater treatment

PT2	PT3	SK	IT	MK
<ul style="list-style-type: none"> <li>✓ Primary treatment - <b>biological treatment in the aeration pond</b> equipped with 4 aerators</li> <li>✓ Secondary treatment - <b>physical-chemical treatment</b> with lime milk and iron chloride, consisting of coagulation / flocculation and sedimentation</li> </ul>	<ul style="list-style-type: none"> <li>✓ <b>primary treatment followed by secondary treatment</b> (biological treatment)</li> <li>✓ Treated wastewaters <b>quality</b> (kg/ton production):                             <ul style="list-style-type: none"> <li>• TSS: 1 ;</li> <li>• COD: 6;</li> <li>• BOD5: 0,5;</li> <li>• AOX: 187;</li> <li>• NTotal/PTotal: 40</li> </ul> </li> </ul>	<ul style="list-style-type: none"> <li>✓ <b>Gravity separation or settling</b></li> <li>✓ <b>Chemical oxidation</b></li> <li>✓ <b>Filtration</b></li> <li>✓ <b>Ion exchange</b></li> <li>✓ <b>Precipitation</b></li> <li>✓ <b>Stripping</b></li> </ul>	<ul style="list-style-type: none"> <li>✓ <b>Primary treatment:</b> API/PPI separators, IAF/DAF flotation, flocculation, clarification and settling system</li> <li>✓ <b>Secondary treatment:</b> active sludges, bio-oxidation, anaerobic, aerobic, nitrification, denitrification treatment</li> <li>✓ <b>Tertiary treatment:</b> sand filters and active carbon beds</li> </ul>	<p>In 2013 untreated wastewater from industry and mining: - 10.9% discharged in public sewers, -52.7% in watercourse -36.4% in reservoirs and the soil.</p> <p>In 2013, there was <b>no discharge of untreated</b> wastewater in the lakes.</p>

Other treatment devices	PT2	SK	IT	MK
Grease interceptor		X	X	
Sand/oil interceptor		X	X	X
Equalization		X	X	
Acid neutralization		X		X
Coagulation/flotation	X	X	X	X
Solids interceptor		X	X	
Other: sedimentation and aeration pond	X			

Use of recovered material from pre-treatment process		
PT2	SK	IT
Dewatered sludge is sent to final destination ( <b>landfill</b> )	<p>Technical material for cover and recultivation <b>landfill</b></p> <p>Use as raw material for <b>production Backfill</b> work</p>	<p>Oily slop from API/PPI system is totally recovered to refinery units inlet to be <b>reprocessed</b>.</p> <p>Oily sludge from thickening treatment is totally recovered as <b>waste</b> in order to produce <b>energy</b> by off-site incineration facilities.</p>

Types of wastewater treatment:

PT2	IT
<p><b>Biological treatment and physico-chemical</b> treatment for waters discharged in the drainage circuit for water transfer to the WWTP.</p> <p>Tertiary treatment, by <b>reverse osmosis</b>, for the treatment of water reused in the industrial process - IIRSU.</p> <p>Treatment of <b>dewatering</b> of sludge with filter</p>	<p>No liquid waste comes from the WWTP</p> <p><b>Oily sludge</b> comes from the thickening treatment line typically by using <b>centrifuge</b> system (non-gravity separation)</p> <p>The expelled water from sludge is then <b>recovered</b> to WWTP inlet</p>

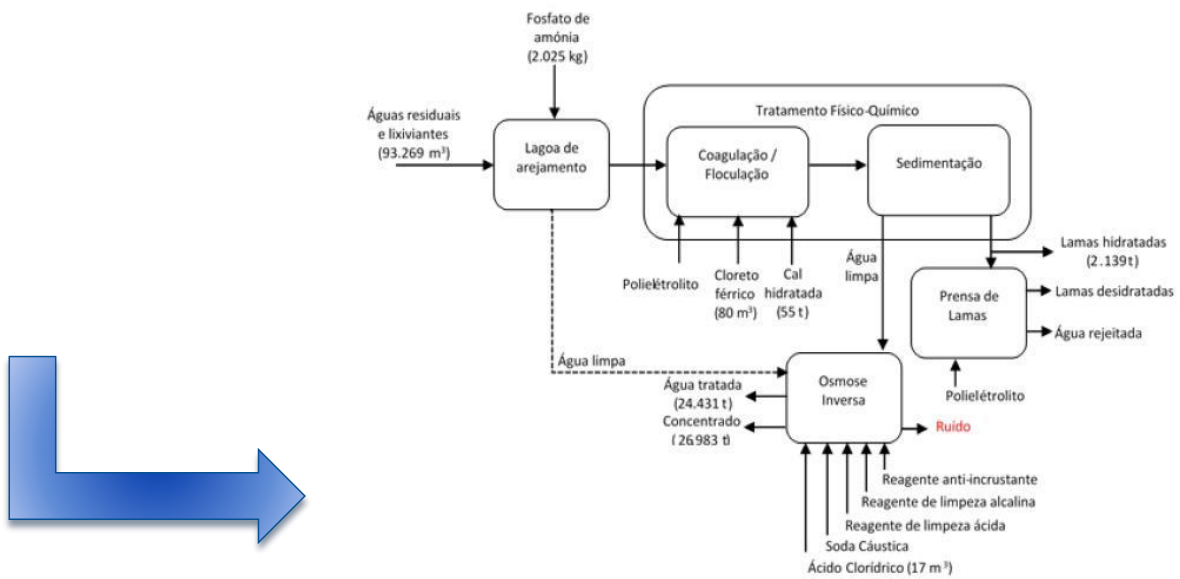

Fig. 9

Innovative technologies:

	PT1	PT2	PT3	SK	IT	ES	MK	UK
<b>Innovative technologies for industrial water treatment</b>		No			No			
<b>Innovative technologies able to provide energy saving, sludge production minimization and re-use of treated wastewaters</b>		No			No		Yes	

## Section F – Wastewater discharge

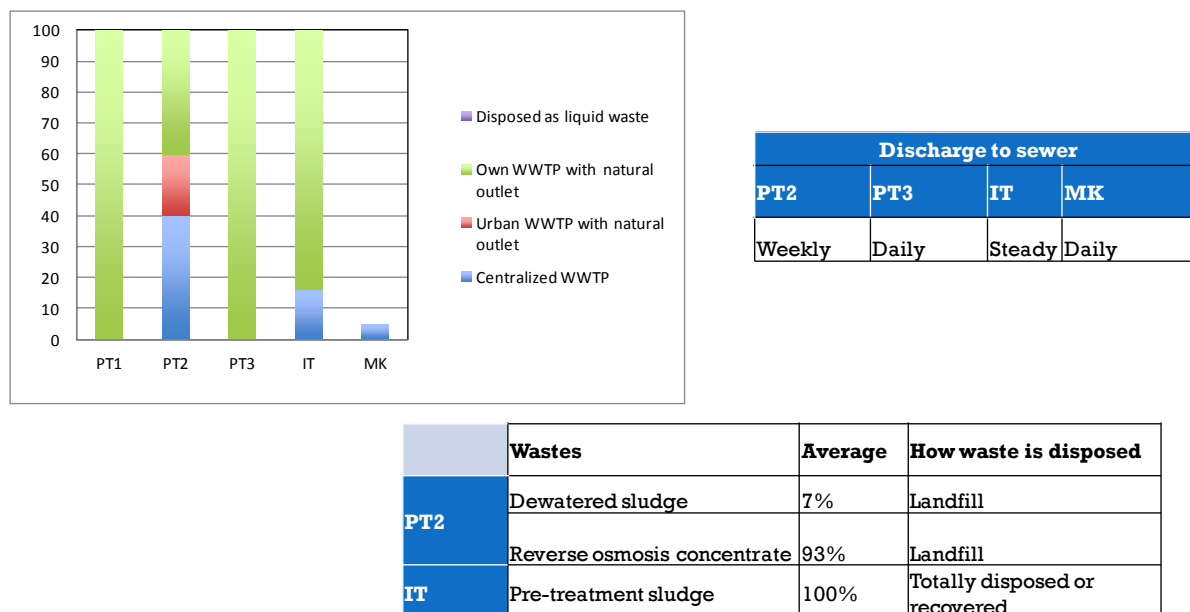

Fig. 10

Concluding, from the responses of the questionnaire we could observe an inhomogeneous transposition of IED and WFD to national legislation. Regarding the EU legislation implementation, in different countries different permitting and inspection procedures have been carried out.

The main categories of activities are Energy Industries (EI), Waste Management (WM), chemical Industry (CI) and others where:

- ✓ the installations relevant in terms of water usage are: EI, CI, others;
- ✓ the installations relevant in terms of water reuse and saving are: EI, WM, others;
- ✓ the installations relevant in terms of wastewater discharge are: EI, others.

Regarding the water usage we could observe:

- ✓ partial reuse in the same industry: 100%;
- ✓ main technologies for water reuse processes: Bio-oxidation and bio-treatment, carbon and chemical treatment, filtration, settling, ion exchange, membrane separation, precipitation;
- ✓ selection of the technology due to: process performance, meets requirements and cost;
- ✓ main motivation for water reuse: cost savings and restricted water supply.

It's widespread in the EU the common wastewater treatment with the traditional primary, secondary and tertiary treatment, while innovative technologies implementation is not diffused.

The common wastewater discharge is the own WWTP with natural outlet and waste are disposed in landfill.

## Water management: Best Available techniques in different industrial sectors

Wastewater management, collection and treatment, as well as water saving measures and reuse, are part of the BAT Conclusions issued for different industrial sectors.

The following BAT Conclusions covering wastewater treatment have been issued so far:

- Decision (EU) 2016/902 (CWW: Common Waste Water and Waste Gas Treatment/Management Systems in the Chemical Sector)
- Decision 2014/687/EU (PP: Pulp and paper)
- Decision 2014/738/EU (REF: Refining of Mineral Oil and Gas)
- Decision 2012/135/EU (IS: Iron and Steel Production)
- Decision (EU) 2017/302 (IRPP: Intensive Rearing of Poultry&Pigs)
- Decision 2013/163/EU (CLM: Production of Cement, Lime and Magnesium Oxide)
- Decision 2013/732/EU (CAK: Production of Chlor-alkali)
- Decision 2013/84/EU (TAN: Tanning of Hides and Skins)
- Decision (EU) 2015/2119 (WBP: Wood-based Panels Production)
- Decision (EU) 2016/1032 (NFM: Non-ferrous Metals Industries)
- Decision 2012/134/EU (GLS: Manufacture of Glass)
- Decision (EU) 2017/1442 (LCP: Large Combustion Plant)

A short description of the BREFs “Pulp and paper” and “Refining of Mineral Oil and Gas” and a list of the main requests of the BAT Conclusions for a proper management of water is given below.

### ***BREF Pulp and paper***

This BREF for Pulp and Paper concerns the activities specified in Sections 6.1.(a) and 6.1.(b) of Annex I to Directive 2010/75/EU, namely:

(a) pulp from timber or other fibrous materials;

(b) paper or cardboard with a production capacity exceeding 20 tonnes per day.

Commission Implementing Decision (EU) 2014/687 of 26 September 2014 established best available techniques (BAT) conclusions for the production of pulp, paper and board.

The techniques listed and described in these BAT conclusions, although generally applicable, are neither prescriptive nor exhaustive. Other techniques may be used that ensure at least an equivalent level of environmental protection.

In particular, to reduce fresh water use and generation of wastewater BAT is to close the water system to the degree technically feasible in line with the pulp and paper grade manufactured by using a combination of the techniques among which:

- Separation of less contaminated sealing water from pumps for vacuum generation and reuse,
- Separation of clean cooling water from contaminated process water and reuse,
- In-line treatment of (parts of) process water to improve water quality to allow for recirculation or reuse.

Also, to reduce the consumption of thermal and electrical energy, BAT is the extensive recovery of secondary heat from TMP and CTMP refiners and reuse of recovered steam in paper or pulp drying.

To reduce the generation of wastewater, BAT is the water recirculation but dissolved organic, inorganic, and colloidal materials may restrict the water reuse in the wire section.

Furthermore, to reduce emission loads of coating colours and binders which can disturb the biological wastewater treatment plant, BAT is Recovery of coating colours/recycling of pigments.

Effluents containing coating colours are collected separately. The coating chemicals are recovered by e.g.: (i) ultrafiltration; (ii) screening-flocculation-dewatering process with return of the pigments to the coating process. The clarified water could then be reused in the process.

Other techniques used to reduce fresh water use/wastewater flow and the pollution load in wastewater could be stripping the contaminated (foul) condensates and reusing the condensates in the process, fibre and filler recovery and treatment of white water - clear white water can be reused in showers with less stringent requirements for water quality – and closed-loop bleaching.

### ***BREF Refining of Mineral Oil and Gas***

This BREF for Refining of Mineral Oil and Gas concerns the activities specified in Sections 1.2 of Annex I to Directive 2010/75/EU, namely “1.2. Refining of mineral oil and gas”.

Commission Implementing Decision (EU) 2014/738 of 9 October 2014 established best available techniques (BAT) conclusions for the refining of mineral oil and gas.

The techniques listed and described in these BAT conclusions, although generally applicable, are neither prescriptive nor exhaustive. Other techniques may be used that ensure at least an equivalent level of environmental protection.

In particular, to reduce water consumption and the volume of contaminated water, BAT is:

- water stream integration: the reduction of process water produced at the unit level prior to discharge by the internal reuse of water streams from e.g. cooling, condensates, especially for use in crude desalting. For existing units, applicability may require a complete rebuilding of the unit or the installation.

- Segregation of non- contaminated water streams (e.g. once- through cooling, rain water): design of a site in order to avoid sending non-contaminated water to general waste water treatment and to have a separate release after possible reuse for this type of stream.

To reduce the amount of sludge to be treated or disposed of BAT is sludge pre-treatment: prior to final treatment (e.g. in a fluidised bed incinerator), the sludges are dewatered and/or de-oiled (by e.g. centrifugal decanters or steam dryers) to reduce their volume and to recover oil from slop equipment.

Other techniques used for the prevention and control of emissions to water could be pre-treatment of sour water streams before reuse or treatment sending generated sour water (e.g. from distillation, cracking, coking units) to appropriate pre-treatment (e.g. stripper unit).

# Principles, requirements, drivers and barriers in industrial water management

## *Principles*

### **REFINING SECTOR**

Reduction of fresh water use is practiced to save money/save energy and for sustainability reasons.

Petroleum industry is definitely aware of the world-wide water shortages and its goal is to prevent critical possible supply restrictions in the future.

Petroleum industry is committed to implement environmental and water stewardships and community outreach through the integration of water resource management and risk assessment throughout the life of operation.

### **PULP&PAPER SECTOR**

Reduction of fresh water use is practiced by recycling the production waters as is common sense in paper production.

Water is the main “carrier” of the papermaking process. Water consumption minimization is at the center of the attention. There is not a new approach but a continuous fine tuning.

Fresh water is directly used only where it is strictly necessary.

Water is so relevant for the process that each and any paper mill periodically makes its own analysis of the water circuits and optimization to reduce water consumption and to guarantee paper quality.

## *Requirements*

### **REFINING SECTOR**

In Italy the permitting process followed derives directly from IED+WFD scheme of adoption.

The Water Reuse target derives from groundwater remediation prescriptions: the groundwater stream has expected to be treated and totally reused for internal needs.

The Water Reuse approach has then extended to the whole refinery streams after WWTP but before the effluent discharge.

In Romania, the National Administration Romanian Waters (NARW) is in charge with permitting, inspection and enforcement of IED installations related to the water management aspects.

NARW is responsible for the implementation of the Water Framework Directive and Floods Directive, as well as for the elaboration of the River Basin Management Plans and of the Flood Risk Management Plans at the river basin level and national level.

In order to assure the implementation and enforcement of the IED, the competent authority – Ministry of Environment and the County Environmental Agencies issue integrate environmental permits only if the IED legal requirements are fulfilled. County Environment Agencies write and enforce the IED permits via a national permitting approach that ensures consistent permits are delivered to Operators. Regarding the water management, the permit, inspection and enforcement is carried out by local branches of NARW based on river catchment/ county boundaries.

In terms of water resources, any kind of use (abstraction, retention, discharges, etc..) requires permit according to the Water Law 107/1996 with further amendments.

The conditions of use are defined taking into account the requirements of the water resources used, namely the water bodies used as water sources and receivers of waste water discharges.

In particular the National Water Strategy for the period 2010–2035 envisages for the refineries:

- Quarterly and Annual monitoring of water withdrawal (requirement of Water Strategy);
- Water Management Plans (requirement of company Water Strategy and Environmental Management Standard).

In Portugal, refineries are under IED (activities listed in Annex I of the IED) and are obliged to comply with water/wastewater requirements; permits and water resources use authorization issued by Portuguese Environment Agency; periodically monitoring and performance report disclosure to Portuguese Environment Agency.

In Cyprus, the IED Directive is implemented via the “Industrial Emissions Law of 2013 No. 184(I)/2013 (Integrated Pollution and Prevention Control). The relevant Authorities for the enforcement of this Law are the Department of Environment and the Department of Labour Inspection. The Department of Environment participates to the steering committee for the implementation of WFD.

The Department of Environment has the responsibility for the control and prevention of water and soil pollution. This is implemented through a permitting and inspection system via the Water



Pollution Control Laws 2002-2013 and the Industrial Emissions Law of 2013 No. 184(I)/2013 (Integrated Pollution and Prevention Control).

Waste Discharge permits are issued according to the Water Pollution Control Laws by the Minister of Agriculture, Rural Resources and Environment.

Industrial Emissions Permits are issued according to the Industrial Emissions Law by the Minister of and the Minister of Labour, Welfare and Social Insurance and the Minister of Agriculture, Rural Resources and Environment.

### **PULP&PAPER SECTOR**

Generally, effluent treatment targets of pulp and paper processors reflect regulatory requirements mandated by corresponding competent authorities. In some cases, effluent limitations for toxic pollutants are set in the wastewater stream discharged directly from the bleaching process and in the final discharge from the mills.

In Germany, the Authority for Industry approval, in collaboration with the trade supervisory board and the lower water authority, is responsible for the monitoring and authorization of water authorities for the industry according to the German IED regulation.

According to the IED regulation there are special monitoring plans, which go with programs for each wastewater treatment plant.

The IED-Guideline has been transposed on national law through legislator. It is transported into the German laws named BImSchG and WHG.

Additionally, requirements of best available techniques (BAT) are integrated into amendments of the regulation of sewage. Normally, national laws are generated by giving water rights through competent water authority. This is the task of the Authority for Industry approval or lower water authorities.

Beyond, the trade supervisory board regulates other, non-water specific approvals.

Normally, every responsible water authority has to control their industrial facilities.

In Portugal, the companies/members are currently subject to strict environmental control resulting from the application of the Industrial Emissions Directive, which obliges them to strictly comply with all requirements applicable to this universe.

All member companies must follow the Water Framework Directive in accordance with the guidelines of the river basin management plans of the regions where they are inserted.

## Drivers

### REFINING SECTOR

The reduction of fresh water use is a goal for most refineries because it is becoming increasingly scarce and the future regulations about water supply will be more and more restricting.

In Italy, the main driver for reusing water in the refineries is the environmental compensation to comply with permit emission limit values. Another driver is the environmental policy and its sustainability approach.

The reduction of fresh water use is a goal for most refineries for two main reasons:

- First, fresh water, particularly high-quality water, is a valuable resource which in many parts of Europe is becoming increasingly scarce (so, the future regulations about water supply will be more and more restricting). Where water of a lower quality is used, treatment to acceptable standards also requires the more use of energy and chemicals.
- Secondly, water used has to be discharged.

The actual BAT-AELs refers to pollutant concentration only [mg/l] regardless of pollutant load [ton/y]. Being equal the pollutant load, Water Reuse approach could be supported by the adoption of a specific K-factor to be applied to BAT-AELs, taking account the water recovery ratio as follow:

$$K = \frac{\text{discharge flow rate with a simple WWTP}}{\text{discharge flow rate adopting WR}}$$

$$\text{BAT-AELWR} = K * \text{BAT-AELWWTP}$$

The Italian refinery representatives suggest to introduce a K-factor for BAT-AELs which proportionally depends on the target of water reuse achieved in a refinery.

In Romania, a driver is the increasing use of desalinated sea water instead of freshwater from public supply, in offshore.

Company HSSE Policy, Water Strategy, Environmental Standard:

- Water reduction targets, water reporting – internal ("HSE Monitor") and external (e.g. to CDP Water, IOGP)
- Rising awareness events (requirement of company Water Strategy, HSSE Policy): water campaign, annual awards for best performance in water management.

In Portugal, the wastewater pre-treatment occurs at the site before it is sent to an external facility for treatment and discharge. The operator has to comply with external entity regulation (entity that receives and treats the wastewater). This regulation sets discharge values for certain pollutants. The operator is taxed based on these values according to the wastewater quality.

Various water saving or recycling solutions have been developed in Germany for the industry. See innovation platform “German Water Partnership”.

## **PULP&PAPER SECTOR**

In Germany the main drivers for reusing water are:

- Regulatory (state, regional or federal) Compliance: 100 %
- Cost Savings
- Corporate Policy

According to the various management systems (BS OHSAS 18001, DIN EN ISO 50001, DIN EN ISO 9001 and DIN EN ISO 14001) the operator follows the continuous improvement approach.

In Portugal the main drivers for reusing water are:

- Regulatory (state, regional or federal) Compliance: 100%
- Cost Savings
- Corporate Policy

In Cyprus the main drivers for reusing water are:

- Regulatory (state, regional or federal) Compliance: 100 %
- Cost Savings

In Latvia the main drivers for reusing water are:

- Regulatory (state, regional or federal) Compliance: 40 %
- Cost Savings
- Community Action

In Slovakia the main drivers for reusing water are:

- Cost Savings
- Corporate Policy

In Italy the main drivers for reusing water are:

- Regulatory (state, regional or federal) Compliance: 0 %
- Cost Savings
- Corporate Policy

## **Barriers**

Despite the water reuse applications already developed in many countries, a number of barriers still prevent the widespread implementation of water reuse throughout Europe and on a global scale. These barriers will have to be overcome if wastewater reuse strategies are to be adopted on a larger and more effective scale than at present, developing the huge eco-innovation potential in terms of technologies and services related to water recycling in industry, agriculture and urban sectors. The main barriers identified are:

- Inconsistent or inadequate water reuse regulations/guidelines, which lead to delays and misjudgements;
- Inconsistent and unreliable methods for identifying and optimising appropriate wastewater treatment technologies for reuse applications, which are able to balance the competing demands of sustainable processes;
- Difficulties in specifying and selecting effective monitoring techniques and technologies for the whole system;
- Significant challenges in reliably assessing the environmental and public health risk/benefit of water reuse across a range of geographical scales;
- Poorly developed business models for water reuse schemes, and markets for reclaimed water;
- Low levels of public and government enthusiasm for water reuse;
- Limited institutional capacity to formulate and institutionalise recycling and reuse measures;
- Lack of financial incentives for reuse schemes.

From a technical standpoint, water reuse is a logical part of the overall water supply and resource management solution. However, technically feasible water reuse projects often do not get implemented due to institutional, economic, and organisational barriers, or poor public perception and education. These non-technical barriers are a limitation to the expansion of water reuse planning.

In April 2016, after the 2015 Communication “Closing the loop - An EU action plan for the Circular Economy”, the European Commission published an Inception Impact Assessment on “Minimum quality requirements for reused water in the EU (new EU legislation)” regarding that the initiative of a regulation on minimum quality requirements for reused water in agricultural irrigation and aquifer recharge may encourage an efficient resource use and will also allow to reduce the pressures on the water environment. Other aims include providing clarity, coherence and predictability to market operators, and complement the existing EU water policy, namely the WFD and the Urban Wastewater Treatment Directive. To support this initiative the European Commission (DG ENV) asked to the Joint Research Centre (JRC) to develop a technical proposal for the minimum quality requirements for water reuse in agricultural irrigation and aquifer recharge, which is currently in the final draft version.

At international level, the Technical Committee on water reuse (TC282) from the International Organization for Standardization (ISO) is developing several standards for water reuse that covers

several areas such as treated wastewater reuse for irrigation, water reuse in urban areas, risk and performance evaluation of water reuse systems, industrial reuse and water systems for biopharma industries. Until now, a standard (with four parts) was already published:

- ISO 16075-1:2015: Guidelines for treated wastewater use for irrigation projects -- Part 1: The basis of a reuse project for irrigation
- ISO 16075-2:2015: Guidelines for treated wastewater use for irrigation projects -- Part 2: Development of the project
- ISO 16075-3:2015: Guidelines for treated wastewater use for irrigation projects -- Part 3: Components of a reuse project for irrigation
- ISO 16075-4:2016: Guidelines for treated wastewater use for irrigation projects -- Part 4: Monitoring.

### **REFINING SECTOR**

In Italy reducing the water volume can lead to increased pollutants concentrations to the effluent water body but the process, if properly designed, can generally deal with this issue.

This rise might put the value for one or several priority substances beyond the Environmental Quality Standard (EQS) of the Water Framework Directive (WFD).

Specific attention should be paid to these cases and could justify a specific study.

### **PULP&PAPER SECTOR**

In Italy, the main limitation to water consumption minimization is the Italian legislation itself as it is based on concentration of pollutants in discharged water.

Water losses in papermaking is the unavoidable evaporation during paper drying. For energy saving needs, energy is recovered as much as possible and low temperature vapour is emitted. This vapour, due to the large quantity is not condensated.

The level of re-use of treated water is already very high (>90%). Water use could not be further reduced without increasing concentration of waste water pollutants.

In Romania, even if the treated wastewater is reused, the amount of sludge increases, does not decrease.

## IED requirements compared to WFD requirements for Industrial Water Management

The purpose of the WFD is to establish a framework for the protection of inland surface waters, transitional waters, coastal waters and groundwater, which inter alia:

- Prevents further deterioration and protects and enhances the status of aquatic ecosystems;
- Promotes sustainable water use based on a long-term protection of available water resources;
- Aims at enhanced protection and improvement of the aquatic environment, namely, through specific measures for the progressive reduction of discharges;
- Ensures the progressive reduction of pollution of groundwater and prevents its further pollution.

And there by contributes to:

- The provision of the sufficient supply of good quality surface water and groundwater as needed for sustainable, balanced and equitable water use, a significant reduction in pollution of groundwater, the protection of territorial and marine waters;
- Cease or phase out discharges, emissions and losses of priority hazardous substances, with the ultimate aim of achieving concentrations in the marine environment near background values for naturally occurring substances and close to zero for man-made synthetic substances.

The IED lays down rules on integrated prevention and control of pollution arising from industrial activities. The aim is to prevent or, where that is not practicable, to reduce emissions into air, water and land and to prevent the generation of waste, in order to achieve a high level of protection of the environment taken as a whole.

Both directives strongly interact, namely, on its article 18, IED requires that where an environmental quality standard (such as those derived from the WFD) requires stricter conditions than those achievable by the use of the BAT, additional measures shall be included in the permits, without prejudice to other measures which may be taken to comply with environmental quality standards. And WFD requires action to be taken on pressures on water bodies (which may include provisions for IED installations).

The IED is focused on the installations and on the rules to control and prevent pollution from those, despite the WFD is supported on the prevention of deterioration of water resources quality and restore polluted waters, which involve ecological and chemical quality for surface waters.

According the WFD all discharges into surface waters shall be controlled according to a combined approach that ensures the emission controls based on BAT, or on relevant emission limit values or in the case of diffuse impacts the controls including, as appropriate, best environmental practices. However, where a quality objective or quality standard requires stricter conditions than those which

would result from the application of previous items, more stringent emission controls shall be set accordingly.

Besides the qualitative aspects, the environmental permitting process for an IED installation also needs to take in account the several water uses already present in the catchment area to ensure that new water abstractions from this installation will not jeopardize the ecological flow of surface waters or the quantitative status of the groundwater body, but usually, the BAT is only focused on the reducing of the fresh water use and generation of wastewater without relationship to the water sources.

Therefore, the single application of the BAT to an installation without linking to the WFD concerns (and other water directives)<sup>1</sup> may not be enough to ensure an adequate level of protection of the receiving water bodies, in terms of water status (qualitative/quantitative) or in terms of the surrounding water use needs.

As illustrated below, the appraisal of the requirements under both directives for the two sectors in study enlarges the need of an integrated approach to ensure that permits are WFD and IED proof:

### **Requirements under IED**

#### *Production of Pulp, Paper and Board*

The BAT-associated emission levels (BAT-AEL) to water applied for this industry are expressed in specific loads, i.e., kg of pollutant per tonne of net production (Air Dry tonnes of pulp expressed as 90 % dryness, ADt) or in mass concentrations, i.e., kg of pollutant per tonne of product, which means that real emissions need to be estimated. These values are also defined for yearly averages. Major parameters with defined BAT-AEL are TSS, COD, BOD<sub>5</sub>, P<sub>total</sub>, N<sub>total</sub> and AOX.

The BAT defines rules for fresh water use reduction but does not reflect any relation with the water status (surface or groundwater status).

#### *Refining of Mineral Oil and Gas*

The BAT-AEL to water applied for this industry reflects flat values expressed in concentrations (mg/L), defined as yearly averages, without previewing any rule for pollutants load reduction or to cease or phase-out the emissions, losses and discharges of priority hazardous substances (mercury and cadmium).

Similar to the Production of Pulp, Paper and Board, the BAT defines rules for fresh water use reduction but does not reflect any relation with the water status (surface or groundwater status).

### **Requirements under WFD**

These industries are considered significant pressures over water resources and need to be addressed under WFD. For their wastewater discharges, adequate emission limit values need to be applied taking into account several aspects, such as:

---

<sup>1</sup> E.g. Groundwater directive, Environmental quality standards directive, Bathing water directive

- The current water status. For water bodies with status below good additional measures are needed to promote its recovery. These measures may already be in place according the respective RBMP;
- Other sources of pollution already in place with permitted discharges to address cumulative load effects;
- The presence of priority hazardous substances on the effluents (e.g. mercury and cadmium in the Refining of Mineral Oil and Gas industries). For these substances additional measures are needed to ensure the compliance of the WFD goals, i.e., cease or phase-out all emissions, losses and discharges of this type of pollutants;
- The presence of priority substances (e.g., benzene, lead and nickel in the Refining of Mineral Oil and Gas industries), other pollutants or specific pollutants on the effluents (e.g. toluene, xylenes, ethylbenzene in the Refining of Mineral Oil and Gas industries, or AOX and disinfection-by-products on the Production of Pulp, Paper and Board). For these substances additional measures are needed to ensure the compliance of the WFD goals, i.e., reduction of the emissions, losses and discharges of this type of pollutants;
- Other uses in presence that may require additional protection. For instance, water abstractions for drinking purposes, fisheries, bathing waters, etc.

Whenever justified, to each discharge a mixing zone (i.e. the zone adjacent to a point of discharge, where the concentrations of one or more substances may exceed the relevant environmental standards if they do not affect the quality of the rest of the water body) should be determined and applied since does not affect the rest of the water body, to avoid to “go beyond BAT” and disproportionate costs. The ELV must also be determined to ensure protection against acute effects (a punctual maximum load/concentration) and chronic effects (a monthly or yearly average concentration).The extent of mixing zones can be determined by several methodologies, such as specific mathematical data or based on a tiered approach, such as the one proposed by the European Commission for the priority substances under the WFD<sup>2</sup>.

Regarding the water abstraction, some precautions must also be taken into account, which inter alia:

- The surface water ecological flow. Whenever justified, the measures for fresh water consumption reduction must be taken according the maintenance of the equilibrium of streams;
- The quantitative status of groundwater and its relation with the respective qualitative status (e.g. areas with saline intrusion risk), the terrestrial groundwater-dependent ecosystems and the current risk of over-exploitation;
- The other water abstractions in presence and its priorities according the respective Member-States national legislation.

A full detailed comparison between IED and WFD requirements can be founded on the phase 1, 2 and 3 reports of the former IMPEL’s Project “Linking WFD and IED” that took place between 2011 to

---

<sup>2</sup> European Commission. “Technical guidelines for the identification of mixing zones pursuant to article 4(4) of the Directive (2008/105/EC)”. Brussels: European Commission, 2010. C(2010) 9369.



2013. Under this project was developed guidance for water management authorities and for IED competent authorities on which attention to information should be put on and on the sharing of information in different phases of their water management cycles and regulatory cycles.

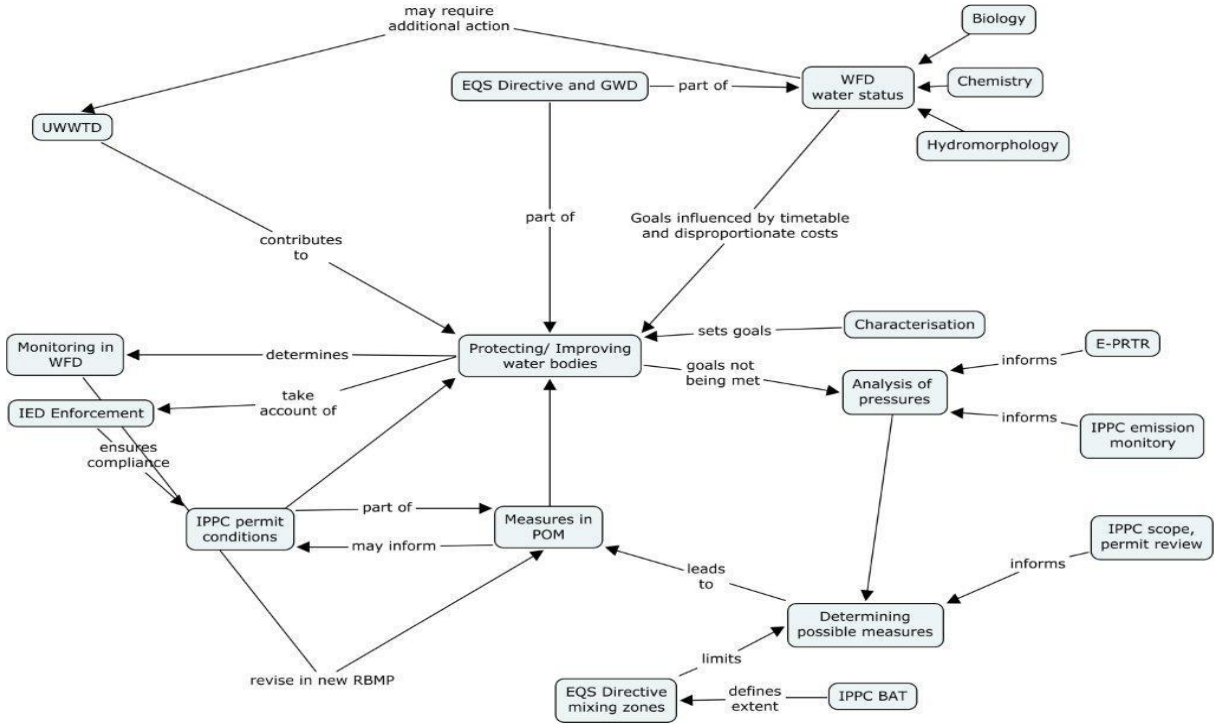

Fig. 11

For this purpose two checklists were provided for both types of authorities.

For water management authorities the checklist is structured around the cycle of river basin planning, namely on the understanding significant water pressures, on establishing and implementing measures and on monitoring:

- Ensuring an appropriate level of knowledge of the IED installations and ensure the integration with the non-IED installations at a catchment and water body scale;
- Promoting the application of ELV on the discharge permits that ensures the compliance of the water status;
- Increasing the level of knowledge on the definition of mixing zones;
- Ensuring that BAT application does not jeopardizes the water status.

The part for IED competent authorities is structured around the regulatory cycle of the IED, i.e.:

- permitting (EP that meets WFD requirements);
- monitoring (avoid programs overlapping and promoting integration of results);
- inspection planning (water bodies key aspects);

- inspection (assess measures to minimize impacts over water bodies);
- permit review (revision according program of measures - RBMP).

The checklists describes the series of actions the relevant authorities may take to aid in their work, including information they could request from other authorities or information they could supply.

## Check list and suggestions for IED permit writers

To ensure that discharge of treated wastewaters included in the environmental licencing process complies with the WFD requirements, some aspects are needed to be checked to guarantee a permitting process both IED and WFD proof. To avoid degradation of the water status, some steps are needed to be taken and for that purpose a check-list for the IED/wastewater discharge permit writers was developed as shown below. Namely, if the water body is in a current status less than good, Member States are obliged to apply measures to revert the situation, and therefore special attention should be taken when wastewater discharge permits are being prepared.

Check-List for water discharge permit writers:

A. Wastewater discharge assessment:

1. Is the water status of the receiving water body less than good? If yes, go to clause 2 and if no, go to the question 1.a.
  - a. Does the BREF document define BAT-AEL that allows the non-deterioration of the water status? If yes, go to the question 5. If no, go to the question 6.
2. Define which are the critical parameters for water body status achievement and go to question 3.
3. Do the wastewaters of the installation contribute to the enrichment of the content of this (these) critical parameter(s)? If yes, go to question 4 and if no, go to the question 1.a.
4. Was (were) defined a BAT-associated emission levels (BAT-AEL) for this (these) parameters on the respective BREF document? If yes go to question 4.a. and if no, go to the question 6.
  - a. Is(are) this(these) value(s) sufficient to contribute for the achievement of the good status? If yes, go to question 5 and if no, go to question 6.
5. Is the reducing of the water consumption and/or promotion of water reuse an obstacle for the ELV (or BAT-AEL) compliance? If yes, go to the question 6 and if no, go to question 8.
6. Can an appropriate Emission Limit Value(s) (ELV) adjusted to the local conditions be defined, according the need of achievement/maintaining the water good status? If yes, go to question 7 and if no, go to question 7.a.
7. If the appropriate ELV, adjusted to the local conditions, achievable and/or affordable? If yes, go to question 7.b. and if no, go to question 7.a,
  - a. Can a mixing zone be applied ? If yes go to question 8 and if no, go to question 10.
  - b. Is a mixing zone advisable? If yes go to 7.a. and if no go to 8.

8. Was a monitoring program, upstream and downstream(outside the exterior limit of the mixing zone, when applicable<sup>3</sup>) defined? (This program will allow to see that the discharge is not contributing to the deterioration of the quality of the water body). If yes, go to clause 9 and if no, go to clause 9.a.
  9. Deliver wastewater discharge permit and assess water body quality evolution through the monitoring results.
    - a. Deliver wastewater discharge permit and assess water body quality evolution through the monitoring results from other programs in place
  10. Is there any possibility of discharges integration and/or to be taken other measures that increase the dispersion of the discharges in the receiving waters? If yes, go to question 8 and if no go to clause 11.
  11. If all fails is not possible to deliver a wastewater discharge permit without risk of jeopardize the goals for the water body under the WFD requirements. (If the all measures that could be applied to the discharge are not enough to ensure achievable/affordable ELV, then appropriate measures must be taken to reduce discharged loads to not jeopardize the goals for the water body under the WFD requirements).
- B. Freshwater consumption assessment:
12. Regarding the freshwater consumption, is its abstraction contributing for endanger of ecological flows (surface water) or the quantitative status (groundwater)? If yes, go to clause 12.a. and if no, go to clause 12.b.
    - a. Define additional measures are needed to reduce water consumption and, in this case, return to question 5.
    - b. No further actions are needed.

---

<sup>3</sup> If a mixing zone is not defined, the environmental standards applied to the water body must be complied at the discharge point.

Check-list's Flow diagram

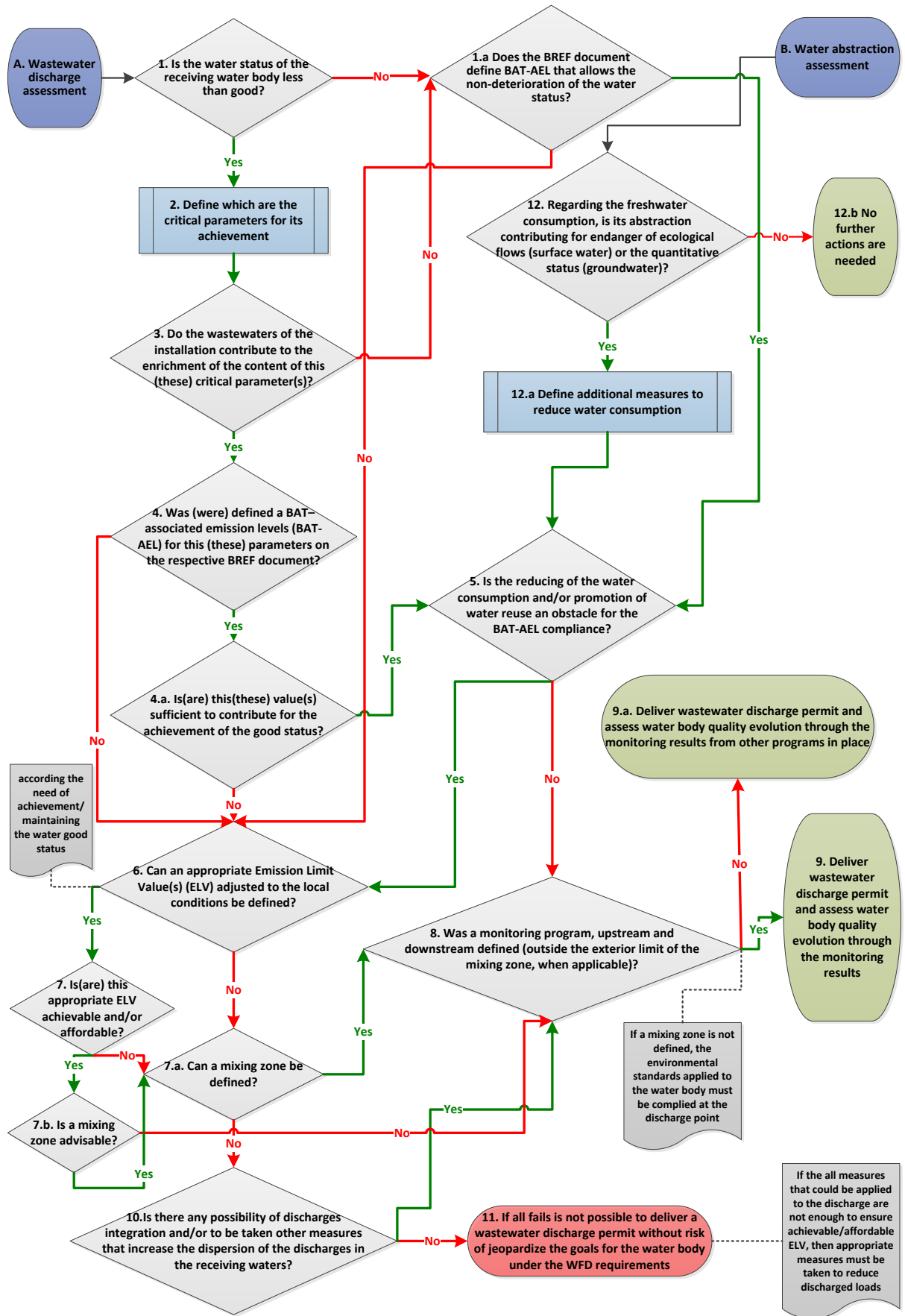

Fig. 12

To ensure that permits are completely IED and WFD proof, besides the above checklist, the guidance of former IMPEL's project "Linking WFD and IED" should also be used<sup>4</sup>.

As an example of application of the check list, if the answers of the questions could be the following

Question 1: NO

Question 1.a: YES

Question 5: NO

than the BAT-AELs should be equal to ELV.

But, regarding ELVs, should they be flat values or fit-for-purpose values ?

In the case of flat values they would be the same for all the installations and locations and could put at risk water bodies status and surrounding uses.

Instead, in the case of fit-for-purpose values, they would ensure protection at local level and adequate installation compliance to local level requirements.

Therefore, the ELVs should always be fit-for-purpose values. On other hand, in the souring area of every discharge, an exceedance zone can occur, i.e., the zone where the treated effluent is not totally mixed with the receiving water. Therefore, to avoid or minimize of going beyond BATs, a mixing zone should be defined whenever possible.

---

<sup>4</sup> IMPEL. "Linking the Water Framework Directive and IED Directive", Report of Phase 3 of the Project. November 2013.

## Conclusions and Recommendations

The recognition that in a growing number of countries large quantities of high quality water may no longer be available at low cost has increased the attention on this topic by regulators and, in particular, by firms in water recycling and reuse.

Such an interest is stimulated by the possible economic feasibility of reuse and recycling but, at the same time, it increases the complexity of designing water catchment area and delivery system, in terms of possible natural sources of water, treatment processes, reuse and/or discharges.

While the role of the water system designer is to optimize the costs-opportunities scenario, the role of the permit writer turns to be critical in stimulating such a virtuous approach and in regulating it.

The first rule, indeed, should be to always ask to the designer, when appropriate, for a comprehensive water management and reuse model within the application for a permit.

Therefore, given a permit application including water management/reuse system design, every permit writer should consider first:

- the whole and integrated approach of the project, in terms of possible natural sources of water, the selection of the chosen water bodies, choices in terms of treatment processes and water deliveries;
- water body status, under the WFD, and water body possible usage;
- different kind of pollutants concerned and related BAT-AELs, ELVs, EQSs; as this guidelines demonstrate, it is critical to know the complexity of pollutants to regulate, their relations to BAT levels and water bodies quality standards, to set case-specific emission limit values; the chapter “Water Management: Best Available techniques in different industrial sectors” of this document gives a brief overview of water management and reuse requirements within the existing BRefs, for the industrial sectors here addressed;
- as the guidelines tried to demonstrate, once the proper water management system has been designed and agreed it becomes critical to manage possible water discharge; particularly permit writers need to understand if and how the application has considered the presence of mixing zones in the water body;
- economics as well as environmental purposes require the optimal definition of the catchment scale to find synergies among installations/sectors, to reduce impacts on water bodies and enhance water reuse.

Understanding and setting the design scenario is important for permit writers in the view of regulating water reuse approach. Generally the starting points should be:

- increase water reuse % versus compliance to BAT-AELs;
- consider maximum admissible values in terms of concentration or mass load to prevent acute effects.
- where it is necessary to go beyond the BAT-AELs;

At the same time the permit writers need to be concerned of:

- economics of the proposed scheme;
- extreme and warning levels of water scarcity situations and consequent water restriction requirements (possible adequate index for the scarcity assessment and for intervention on the authorization conditions);
- situations when pollutant discharge load restrictions or when pollutant emission factors are to be applied;
- setting specific authorization conditions for water reuse in different cases of discharge (in sea waters, in river waters, in natural/artificial reservoirs, in external/consortium based wastewater treatment plants).

For the future applications it is possible to envisage an even complex scenario, that will give anyway several possibilities.

The circular economy approach and synergies among installations located in the same area (reuse of wastewaters in other neighbour plants), as well as among different sectors (reuse of wastewaters for different purposes i.e. industrial, agricultural, commercial, urban, etc.) will play a main role.

It could be foreseen possible incentives or funds granting for installations implementing water reuse and environmental compensation.

System designers, as well as permit writers, will deal in the future with:

- water master plan, water usage optimisation scheme and water stream integration at policy and at unit operation level; just because of the need to minimize costs, designers will use, more and more in the future, specific assessment tools, mainly based on the principle of process integration and water pinch analysis, with the aim to identify and quantify possible solutions; it is expected a major role also for permit writers in understanding and regulating the use of the new instruments;
- possible increasing restrictions on water supply, and therefore increasing of supply costs, or possible fresh water usage ban, obligation of rainwater usage, obligation of storage of treated wastewaters, will probably enlarge the number of industrial sectors interested to address the issue of water management and reuse as well as



the development of ultra-treatment of polluted/draught internal water and techniques of basin refill;

- regulation updates that could arise, exploring for example the dilution with cooling or domestic waters, after the sampling-point and before discharge-point, in order to decrease possible peak pollutants concentration in the outflow area of the receiving water bodies or exploring new uptake schemes of the water to be reused, for example downstream with respect to the discharge point or discharge flux.

The second phase of the project in 2018 will address future expectations.

## ANNEXES

1. ToR
2. QUESTIONNAIRES SCHEME
3. CASE STUDIES

**Annex 1 – ToR**

TOR Reference No.: 2017/09	Author(s): Geneve Farabegoli
Version: 2	Date: November 2016
<b>TERMS OF REFERENCE FOR WORK UNDER THE AUSPICES OF IMPEL</b>	

**1. Work type and title:**

Introducing an integrated approach for water saving and reuse

<b>1.1 Identify which Expert Team this needs to go to for initial consideration</b>	
Industry	<input type="checkbox"/>
Waste and TFS	<input type="checkbox"/>
Water and land	<input checked="" type="checkbox"/>
Nature protection	<input type="checkbox"/>
Cross-cutting – tools and approaches -	<input type="checkbox"/>
<b>1.2 Type of work you need funding for</b>	
Exchange visits	<input type="checkbox"/>
Peer reviews (e.g. IRI)	<input type="checkbox"/>
Conference	<input checked="" type="checkbox"/>
Development of tools/guidance	<input checked="" type="checkbox"/>
Comparison studies	<input checked="" type="checkbox"/>
Assessing legislation (checklist)	<input checked="" type="checkbox"/>
Other (please describe):	<input type="checkbox"/>
	<input type="checkbox"/>
<b>1.3 Full name of work (enough to fully describe what the work area is)</b>	
Sharing good practices in industrial water treatment and reuse implementing multiple EU requirements	
<b>1.4 Abbreviated name of work or project</b>	
Water saving& reuse	

## 2. Outline business case (why this piece of work?)

<b>2.1 Name the legislative driver(s) where they exist (name the Directive, Regulation, etc.)</b>	
Water Framework Directive (WFD), Directives on Nitrates, Urban Wastewater Treatment Directive, Industrial Emissions Directive (IED)	
<b>2.2 Link to IMPEL MASP priority work areas</b>	
1. Assist members to implement new legislation	<input checked="" type="checkbox"/>
2. Build capacity in member organisations through the IMPEL Review Initiatives	<input type="checkbox"/>
3. Work on 'problem areas' of implementation identified by IMPEL and the European Commission	<input checked="" type="checkbox"/>
<b>2.3 Why is this work needed? (background, motivations, aims, etc.)</b>	
<p>More than 15 years after the emanation of several major Directives, including the Water Framework Directive (WFD), Directives on Nitrates, Urban Wastewater Treatment Directive, as well as the Integrated Pollution Prevention and Control Directive (IPPC) now replaced by the Industrial Emissions Directive, their objectives remain to be fully achieved in many Member States. In particular the implementation of EU legislation on water and land has been identified as one of the top challenges in recent IMPEL research because of some problems at several levels such as: the transposition of EU legislation into national laws; the setting of environmental objectives and plans in Member States; the enforcement of the requirements, for example through permitting and inspection regimes.</p> <p>The objective of this project is to identify, both from the regulatory that technological point of view, how the water resource is managed today in the industry sector subject to the Integrated Environmental Permitting (IEP) regulation.</p> <p>The main aim of the project is to compare and share among the IMPEL members the implementation of EU legislation relating to water resources management and protection in industrial installations and activities. New approaches for reducing fresh water consumption and over-abstraction of water are to be identified, enhancing water reuse through process analysis, water balance and utilities optimization.</p> <p>This project is also focused on the implementation of innovative technologies for industrial water treatment able to provide energy saving, sludge production minimization and re-use of treated wastewaters, allowing to respect the required discharge limits.</p>	
<b>2.4 Desired outcome of the work (what do you want to achieve? What will be better / done differently as a result of this project?)</b>	
<p>A survey of activities on problems and best practices in industrial water treatment and reuse area will be carried out by IMPEL members. Several case studies/experiences will be presented and common findings will be shared.</p> <p>The outcomes of the activities will be delivered through the development of guidance documents and manuals, meeting, conferences and technical workshops.</p>	
<b>2.5 Does this project link to any previous or current IMPEL projects? (state which projects and how they are related)</b>	
No	

### 3. Structure of the proposed activity

<b>3.1 Describe the activities of the proposal (what are you going to do and how?)</b>
<ul style="list-style-type: none"> <li>○ Survey made by the use of a questionnaire</li> <li>○ 1 project meeting to discuss questionnaire results</li> <li>○ New approach identification</li> <li>○ Draft guidance document</li> <li>○ 1 project meeting to review draft guidance</li> <li>○ Final guidance document</li> <li>○ Presentation at the final workshop</li> </ul>
<b>3.2 Describe the products of the proposal (what are you going to produce in terms of output / outcome?)</b>
Final guidance document
<b>3.3 Describe the milestones of this proposal (how will you know if you are on track to complete the work on time?)</b>
2* Project meeting Interim reports Final guidance document Final workshop
<b>3.4 Risks (what are the potential risks for this project and what actions will be put in place to mitigate these?)</b>
Low risk project

### 4. Organisation of the work

<b>4.1 Lead (who will lead the work: name, organisation and country)</b>
Geneve FARABEGOLI - Italian National Institute for Environmental Protection and Research, ISPRA - Italy
<b>4.2 Project team (who will take part: name, organisation and country)</b>
Team leader and other participants (contacts already established with Netherlands): Albert Avellaneda Bargués - Generalitat de Catalunya, Spain Anabela Rebelo APA – Portuguese Environmental Agency State Environmental Inspectorate, the former Yugoslav Republic of Macedonia National Environmental Guard, Romania
<b>4.3 Other IMPEL participants (name, organisation and country)</b>
Organizations and individuals involved in environmental permitting, monitoring, compliance promotion and assessment, enforcement action.
<b>4.4. Other non-IMPEL participants (name, organisation and country)</b>
Possible partnerships include IPPC Bureau, European Environmental Agency and industry sector associations.

**5. High level budget projection of the proposal. In case this is a multi-year project, identify future requirements as much as possible**

	Year 1 (exact)	Year 2	Year 3	Year 4
How much money do you require from IMPEL?	18185			
How much money is to be co-financed	0			
<b>Total budget</b>	18185			

**6. Detailed event costs of the work for year 1**

	Travel € (max €360 per return journey)	Hotel € (max €90 per night)	Catering € (max €25 per day)	Total costs €
<b><u>Event 1</u></b>	1440 (4*360)	720 (4*2*90)	125 (5*25)	2285
<i>Project Meeting</i>				
<i>May 2017</i>				
<i>Rome</i>				
<i>5</i>				
<i>2 nights accommodation</i>				
<b><u>Event 2</u></b>	1440 (4*360)	720 (4*2*90)	125 (5*25)	2285
<i>Project Meeting</i>				
<i>October 2017</i>				
<i>Rome</i>				
<i>5</i>				
<i>2 nights accommodation</i>				
<b><u>Event 3</u></b>	8640 (24*360)	4320 (24*2*90)	625 (25*25)	13585
<i>Final Workshop</i>				
<i>End of 2017</i>				
<i>Rome</i>				
<i>25</i>				
<i>2 nights accommodation</i>				
<b><u>Total costs for all events</u></b>	11520	5760	875	18155

**7. Detailed other costs of the work for year 1**

<b>7.1 Are you using a consultant?</b>	<input type="checkbox"/> Yes <input checked="" type="checkbox"/> No
<b>7.2 What are the total costs for the consultant?</b>	
<b>7.3 Who is paying for the consultant?</b>	
<b>7.4. What will the consultant</b>	

<b>do?</b>	
<b>7.5 Are there any additional costs?</b>	<input type="checkbox"/> Yes <input checked="" type="checkbox"/> No Namely:
<b>7.6 What are the additional costs for?</b>	
<b>7.7 Who is paying for the additional costs?</b>	
<b>7.8. Are you seeking other funding sources?</b>	<input type="checkbox"/> Yes <input checked="" type="checkbox"/> No Namely:
<b>7.9 Do you need budget for communications around the project? If so, describe what type of activities and the related costs</b>	<input type="checkbox"/> Yes <input checked="" type="checkbox"/> No Namely:

## 8. Communication and follow-up (checklist)

	What		By when
<b>8.1 Indicate which communication materials will be developed throughout the project and when</b>  <i>(all to be sent to the communications officer at the IMPEL secretariat)</i>	TOR <sup>✓*</sup> Interim report <sup>✓*</sup> Project report <sup>✓*</sup> Progress report(s) <sup>✓</sup> Press releases News items for the website <sup>✓*</sup> News items for the e-newsletter Project abstract <sup>✓*</sup> IMPEL at a Glance <sup>✓</sup> Other, (give details):	<input checked="" type="checkbox"/> <input checked="" type="checkbox"/> <input checked="" type="checkbox"/> <input type="checkbox"/> <input type="checkbox"/> <input checked="" type="checkbox"/> <input type="checkbox"/> <input checked="" type="checkbox"/> <input checked="" type="checkbox"/> <input type="checkbox"/>	01/01/17 31/05/17 31/10/17 - - 31/10/17 - 31/10/17 31/10/17
<b>8.2 Milestones / Scheduled meetings (for the website diary)</b>	Questionnaire in/out Project Meeting x2 Autumn ET meeting Final Workshop		
<b>8.3 Images for the IMPEL image bank</b>	<input type="checkbox"/> Yes <input checked="" type="checkbox"/> No		
<b>8.4 Indicate which materials will be translated and into which languages</b>	Project abstract (dependent on project team members)		
<b>8.5 Indicate if web-based tools will be developed and if hosting by IMPEL is required</b>	No		
<b>8.6 Identify which groups/institutions will be targeted and how</b>	All IMPEL members via questionnaire		
<b>8.7 Identify parallel developments / events by other organisations, where the project can be promoted</b>			

<sup>✓</sup>) Templates are available and should be used. <sup>\*</sup>) Obligatory



## 9. Remarks

*Is there anything else you would like to add to the Terms of Reference that has not been covered above?*

*In case of doubts or questions please contact the  
IMPEL Secretariat.  
Draft and final versions need to be sent to the  
IMPEL Secretariat in word format, not in PDF.  
Thank you.*



European Union Network for the Implementation  
and Enforcement of Environmental Law

# Questionnaire

---

Integrated water approach

2017/10

**March 16, 2017**

**Version 1.2**

# TABLE OF CONTENTS

---

1. Introduction
  2. Explanation
  3. Glossary of Terms
  4. Questions
    - 4.1. Section A – General information
    - 4.2. Section B – Regulation
    - 4.3. Section C – Plant operational characteristics
    - 4.4. Section D – Water usage
      - Water source
      - Water reuse
    - 4.5. Section E – Wastewater treatment
    - 4.6. Section F – Wastewater discharge
- Annex I. Flow diagrams

## 1. Introduction

More than 15 years after the emanation of several major Directives, including the Water Framework Directive (WFD), Directives on Nitrates, Urban Wastewater Treatment Directive as well as the Integrated Pollution Prevention and Control Directive (IPPC) now replaced by the Industrial Emissions Directive (IED), their objectives remain to be fully achieved in many Member States.

In particular the implementation of EU legislation on water and land has been identified as one of the top challenges in recent IMPEL research because difficulties at several levels such as the transposition of EU legislation into national laws as well as the setting of environmental objectives and plans in Member States and the enforcement of the requirements, for example through permitting and inspection regimes.

In this framework, recently, the IMPEL-project “Integrated water approach” took off.

Integrated water approach is a one-year project that has the following aims:

- 4) to collect and compare the procedures that are used within Europe for water resources management and protection in the industry sector;
- 5) to identify new approaches for reducing fresh water consumption and innovative technologies for industrial water treatment able to provide energy saving, sludge production minimization and water reuse for multiple purposes;
- 6) to use this information for developing a guidance document to share among IMPEL members and other non-IMPEL participants including for example the IPPC Bureau, European Environmental Agency and industry sector associations.

This questionnaire will be used to collect the information on water management in industry within EU. We do not intend to be fully complete and cover all the issues concerning water management but will help us to organize a workshop, that is planned for the end of 2017 in Italy, where the guidance document will be presented. The questionnaire should be filled in by people that are responsible or involved in environmental permitting, monitoring, compliance promotion and assessment, enforcement action, industry sector associations etc. To help you better understand what the project is about, the following section explains the main topics the project is focusing on and provides some working definitions used in the project.

If necessary, please consult your colleagues when filling in the questionnaire to get a representative picture of the situation in your country. Send your filled in questionnaire to Genève Farabegoli before **18<sup>th</sup> April 2017**, via e-mail: [geneve.farabegoli@isprambiente.it](mailto:geneve.farabegoli@isprambiente.it).

## 2. Explanation

While it is important that approaches to water resources management are suited to the individual circumstance of a country and a local region, it has been widely recognized that traditionally fragmented or purely single media approaches are no longer viable. This is due to the challenges created by increasing and often conflicting demands on water resources that are further complicated by climate change. The best management practices are those based on integrated approaches that try to combine and balance both social and environmental needs.

This project will not only look at the implementation of EU legislation on water resources management and protection in the industry sector comparing different procedures that are used

within Europe, but will also look at new integrated approaches and innovative technologies for industrial water treatment, water re-use and energy saving coming out from the industrial sector.

The questions are divided in different sections.

- Section A – General information
- Section B – Regulation
- Section C – Plant operational characteristics
- Section D – Water usage
- Section E – Wastewater treatment
- Section F – Wastewater discharge

In section A we ask you to introduce yourself and your organization. In section B we ask you to describe how the EU legislation on water resources management and protection is implemented in the industry sector, in your country. In section C we ask you more about the plant operational characteristics. In section D (water supply and reuse), E (generated wastewater treatments) and F (effluent discharge) we refer to a real installation that can be considered as an example for best practices. Anyway, if you have several examples of homogeneous installations adopting same techniques of water management, the description could not necessarily be related to a real installation, but it could be representing the average values of installations having the same characteristics.

### 3. Glossary of Terms

**Centralized WWTP** – Any wastewater treatment plant that receives a wide variety of hazardous and non-hazardous industrial wastewaters for treatment from other industries.

**Discharge** - The disposal of any sewage, pollutant(s), water or any liquid from any sewer user into the sewerage system.

**IED:** Industrial Emissions Directive - Directive 2010/75/EU on industrial emissions (Integrated Pollution Prevention and Control).

**Natural outlet** - Any outlet into a water course, ditch, or other body of surface or ground water.

**Pre-treatment** - The physical, chemical, biological or other treatment of any industrial discharge prior to discharge to the sewer, for the purpose of:

- (a) Reducing the amount or concentration of any pollutant; or
- (b) Eliminating the discharge or any pollutant; or
- (c) Altering the nature of any pollutant characteristic to a less harmful state.

**Relevant** – Everything is relevant in terms of quality and quantity.

**Sewer** - A sewer which carries sewage and to which storm, surface and ground waters are not intentionally admitted.

**Water reuse** - Use of treated wastewater for beneficial use; synonymous also to water reclamation and water recycling.

**Wastewater** - Water arising from any combination of domestic, industrial or commercial activities, which may include surface runoff and any accidental sewer inflow/infiltration water and which can include collected storm water, discharged to the environment or sewer.

**Wastewater treatment** – Any treatment of any industrial wastewater including liquid waste as well as sludge.

**WFD** – Water Framework Directive - Directive 2000/60/EC of the European Parliament and of the Council establishing a framework for the Community action in the field of water policy.

## 4. Questions

### 4.1 Section A – General information

<b>Name</b>	
Organization	
Address	
Telephone	
E-mail	
Country	
Level	<input type="checkbox"/> National or State level
	<input type="checkbox"/> Regional or Provincial level
	<input type="checkbox"/> Local level
Function or position	
Remarks	

*Any extra remarks you would like to make about your role, responsibility or involvement in the industry water management sector.*

## 4.2 Section B – Regulation

1a Please describe how your organization is involved in IED enforcement.

1b Please describe how your organization is involved in WFD enforcement.

2 Please report the number of installations under IED, WFD, IED + WFD in your interest area of your country.

IED	<input type="checkbox"/> < 100	<input type="checkbox"/> 100-150	<input type="checkbox"/> > 150
WFD	<input type="checkbox"/> < 100	<input type="checkbox"/> 100-150	<input type="checkbox"/> > 150
IED+WFD	<input type="checkbox"/> < 100	<input type="checkbox"/> 100-150	<input type="checkbox"/> > 150

3 How the EU legislation relating to water resources management and protection is implemented in industrial installations and activities in your country ?

*For example describe who is responsible for policy making, permitting, inspection and enforcement.*

4 Referring to installations of item B2, how the compliance to EU legislation described in item B3, is ensured ?

5 Please briefly describe the permitting process system, from application to decision, in your country.

If possible please provide a flowchart of your permitting process in the Annex

### 4.3 Section C – Plant operational characteristics

1 Please briefly estimate the percentage distribution of installations of item B2 within the following categories.

*Categories of activities could be:*

- *EI – Energy industries*
- *PM - Production and processing of metals*
- *MI - Mineral industry*
- *CI - Chemical industry*
- *WM- Waste management*
- *Other activities*

EI: \_\_\_\_\_ %  
PM: \_\_\_\_\_ %  
MI: \_\_\_\_\_ %  
CI: \_\_\_\_\_ %  
WM: \_\_\_\_\_ %  
Other activities (list): \_\_\_\_\_%

2 Referring to the percentage distribution of installations of item B2, how many installations are relevant in terms of water usage ?

*Please briefly describe how they are relevant*

3 Referring to the



percentage distribution of installations of item B2, how many installations are relevant in terms of water reuse and saving?

*Please briefly describe how they are relevant*

4 Referring to the percentage distribution of installations of item B2, how many installations are relevant in terms of wastewater discharge?

*Please briefly describe how they are relevant*

#### 4.4 Section D – Water usage

As detailed in the explanation chapter, in this section we refer to a real installation that can be considered as an example for best practices. Anyway, if you have several examples of homogeneous installations adopting same techniques of water management, the description could not necessarily be related to a real installation, but it could be representing the average values of installations having the same characteristics.

#### Water source

1 Check where appropriate water supply.

	Percentage
Water piped network:	
- Potable water _____ %	
- Non potable water _____ %	
Freshwater:	
- Groundwater (drilled wells/boreholes) _____ %	
- Surface water _____ %	

2 Which is the average amount of water supplied per year ?

Value	Unit of measure
_____	_____

3 Water is used for:

Water for industrial use: _____ %
Water for domestic use: _____ %
Water losses: _____ %
Water discharged: _____ %

4 Please briefly describe any raw water treatment process in use and what manufacturing process this treated water is used for.

--

5 Have new approaches for reducing fresh water consumption and over-abstraction of water been implemented ?

<input type="checkbox"/> Yes
<input type="checkbox"/> No

*If Yes, please describe which one*

6 Please briefly describe any measure adopted for minimizing water losses.

--

### Water reuse

7 Number of water reuse processes or technologies.

<input type="checkbox"/> 1	<input type="checkbox"/> 2	<input type="checkbox"/> 3	<input type="checkbox"/> 4	<input type="checkbox"/> 5	<input type="checkbox"/> > 5
----------------------------	----------------------------	----------------------------	----------------------------	----------------------------	------------------------------

*If possible please provide a flow diagram for each reuse process in the Annex.*

## Water reuse

*Please briefly describe*

--

- 8 Referring to item D7 please indicate the extent of water reuse, specifying if the water is reused in the same industry or for a different purpose.**

Partial Reuse in the same industry: _____ % Partial Reuse outside the industry: _____ % (Please specify for which purpose) _____
Total Reuse, Zero Water Discharge in the same industry: _____ % Total Reuse, Zero Water Discharge outside the industry: _____ % (Please specify for which purpose) _____

- 9 Please check which technologies are used for water reuse processes.**

Bio-oxidation and bio-treatment (anaerobic, aerobic, nitrification, other)	
Carbon treatment (sorption or adsorption)	
Centrifuge (non-gravity separation)	
Chemical oxidation (ozone, wet air, peroxide, super-critical, other)	
Chemical treatment (chlorination, conversion, other)	
Crystallization	
Electrodialysis	
Evaporation (mechanical, ponds, distillation)	
Filtration (granular bed, vacuum drum, press, belt filter, other)	
Flotation	
Gravity separation or settling (coagulation, flocculation or clarification)	
Ion exchange	
Membrane separation (reverse osmosis, ultrafiltration)	
Precipitation	
Solidification or stabilization	
Solvent extraction	
Stripping (steam, air, other)	
Thermal treatment (drying, incineration, spray drying, other)	
Other (describe: _____)	

- 10 Please indicate the motivation for water reuse by checking all that apply.**

Regulatory (state, regional or federal) Compliance: _____ %  Cost Savings: <input type="checkbox"/>  Corporate Policy: <input type="checkbox"/>
---

Community Action:

Restricted Water Supply:

Other, describe: \_\_\_\_\_

**11 Identify the basis for selection of the chosen technologies:**

Cost:

Process Performance / Meets Requirements:

Other Regulatory Requirement (describe): \_\_\_\_\_

**12 Have process analysis, water balance and utilities optimization to enhance water reuse been done ?**

Yes

No

*If Yes, please describe which one*

#### 4.5 Section E – Wastewater treatment

As detailed in the explanation chapter, in this section we refer to a real installation that can be considered as an example for best practices, that you already described in section D. Anyway, if you have several examples of homogeneous installations adopting same techniques of water management, the description could not necessarily be related to a real installation, but it could be representing the average values of installations having the same characteristics, as you did in section D.

**1 Please describe the types of pre-treatment used before discharge, including the water treatment quality standards applied.**

**2a Please check which of the following other treatment devices are used.**

Grease interceptor:

Sand/oil interceptor:

Equalization:

Acid neutralization:

Coagulation/flotation:

Solids interceptor:

Other (list):

**2b Please briefly describe the possible use of recovered material from any pre-treatment process.**

**3 Please describe the types of wastewater treatment used considering both liquid waste and sludge treatment.**

*If possible please provide a flow diagram for each wastewater treatment in the Annex*

**4 Have some innovative technologies for industrial water treatment been implemented ?**

- Yes
- No

*If Yes, please describe which one*

**5 Are the innovative technologies able to provide energy saving, sludge production minimization and re-use of treated wastewaters ?**

- Yes
- No

*If Yes, please describe which technology is used and the recovery percentage reached during time*

**4.6 Section F – Wastewater discharge**

In this section, in item F1 please provide general information related to section B. Following, in the remaining part of section F we refer to a real installation that can be considered as an example for best practices, that you already described in section D and section E. Anyway, also in this case, if you have several examples of homogeneous installations adopting same techniques of water management, the description could not necessarily be related to a real installation, but it could be representing the average values of installations having the same characteristics, as you did in section D and section E.

**1 Referring to the percentage distribution of installations of item B2, which percentage of installations discharges to a centralized WWTP, to a natural outlet or disposes wastewaters as liquid waste ?**

Centralized WWTP: \_\_\_\_\_ %

Urban WWTP with natural outlet: \_\_\_\_\_ %

Own WWTP with natural outlet: \_\_\_\_\_ %

Disposed as liquid waste: \_\_\_\_\_ %

**2 Is discharge to sewer:**

Intermittent:

Discharge frequency: Daily  Weekly  Monthly

Other (describe) \_\_\_\_\_

Steady:

**3 With reference to waste liquids or sludges generated, please briefly describe as provided in the table:**

Wastes	Average %	How waste is disposed ?
Waste solvent		
Oil/grease		
Pre-treatment sludge		
Acids and alkalis		
Other (specify):		

### **Annex 3 – CASE STUDIES**

Among the 14 questionnaires three are relative to the Refinery sector and three to the Pulp & Paper sector. We received only one questionnaire coming from a company treating industrial effluent from tanneries and none from the textile sector.

Consequently we decided to focus this GL only for the refinery and the pulp&paper sectors.

The following case studies are presented.

#### **REFINERY SECTOR**

- 1) Case study A
- 2) Case study B
- 3) Case study C

#### **PULP&PAPER SECTOR**

- 4) Case study D
- 5) Case study E
- 6) Case study F



## REFINERY SECTOR

### CASE STUDY A

#### Water usage

In this kind of industry the average amount of water supplied is 7.750.000 m<sup>3</sup>/year (2015 final balance of a refinery) of which the higher amount comes from the water piped network: non potable water (98 %) and equally distributed between groundwater (drilled wells/boreholes 42%) and surface water (58%). Water is mainly used for industrial purpose (47%) and the other amount is discharged once used.

The industrial raw water is collected to physical-chemical treatment step in order to produce process water and boiling feed water. Ion exchange resins, ultrafiltration and reverse osmosis techniques are often used for water reuse and boiling feed water make-up. The refining sector has often implemented, where feasible, water reuse plants in order to reduce fresh water consumption.

One of the main water loss in the refining sector is the steam losses from process piping/equipment. In order to minimize water losses and save energy, refineries are consistently increasing the amount of recycled water by means of steam condensation recovery from pipes/equipment.

#### Water reuse

The Water Reuse target derives from groundwater remediation prescriptions: the groundwater stream has expected to be treated and totally reused for internal needs.

The Water Reuse approach has then extended to the whole refinery streams after WWTP but before the effluent discharge.

The refining sector often adopts the following main technologies for water reuse obtaining a partial reuse in the same industry of about 100 %:

1. Sand filters
2. Granular active carbons
3. Ion exchange resins
4. Ultrafiltration
5. Reverse osmosis.

As previously mentioned in the paragraph Drivers and Barriers, the main driver for reusing water in refineries is the environmental compensation to comply with permit emission limit values. Another driver is the environmental policy and its sustainability approach.

Water mass balance has always carried out in order to enhance water reuse and to comply with emission limit values before discharge to the receiving water body.

This flow diagram compares “simple WWTP” versus “combined WWTP + WR” as indicated in figure A1:

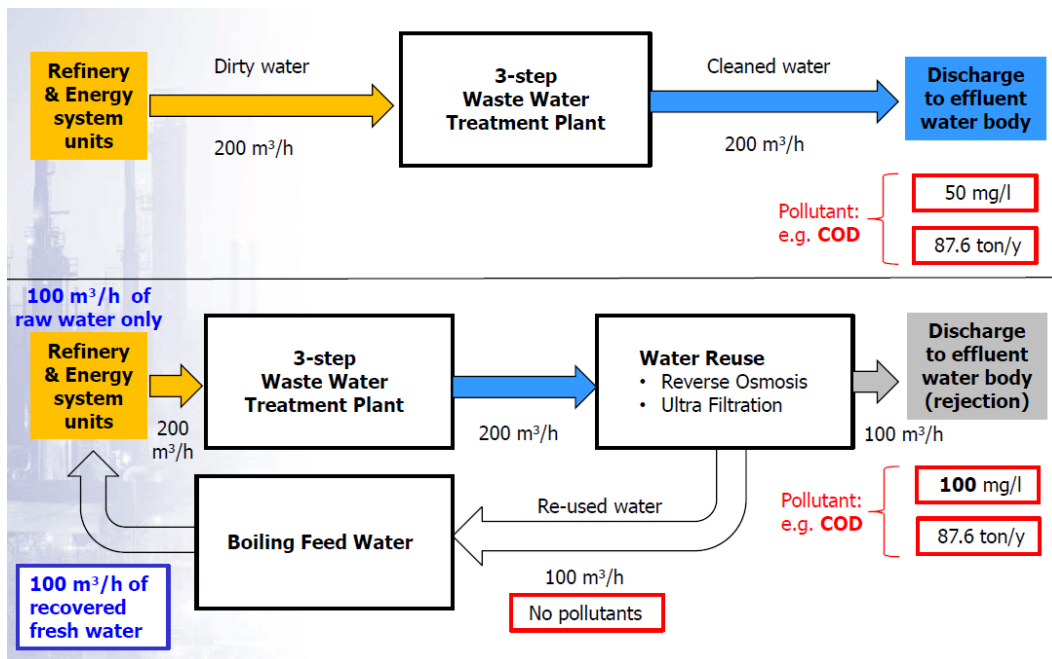

Fig. A1

### Wastewater treatment

The refining sector applies the BAT (Best Available Techniques) for Waste Water Treatment Plant (WWTP) which often involves the following main steps:

- Primary treatment: API/PPI separators, IAF/DAF flotation, flocculation, clarification and settling system
- Secondary treatment: active sludges, bio-oxidation, anaerobic, aerobic, nitrification, denitrification treatment
- Tertiary treatment: sand filters + active carbon beds
- Water Reuse: reverse osmosis + ultrafiltration.

This flow diagram deals with a typical WWTP configuration always present in refineries, as indicated in figure A2:

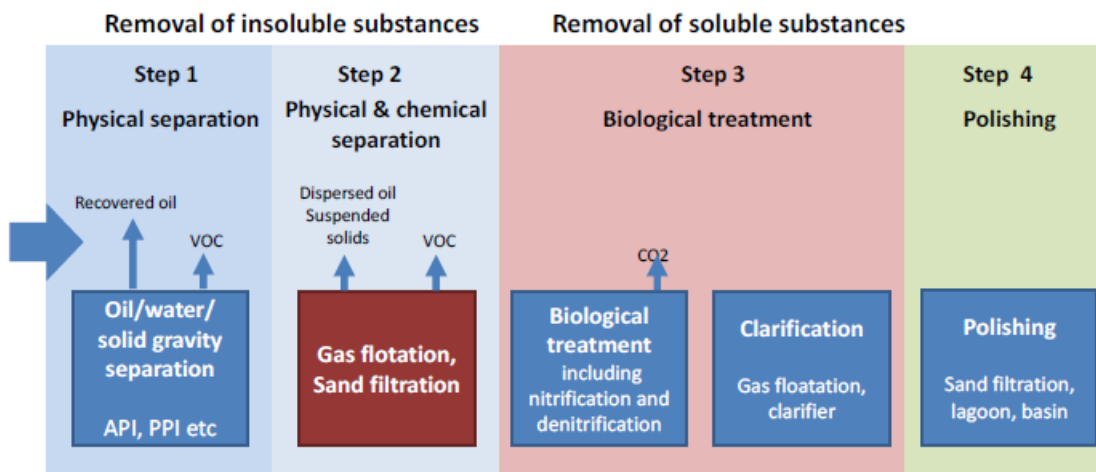

Fig. A2

All water treatment facilities meet the effluent quality targets required by law before discharge to the receiving water body.

The possible use of recovered material from any pre-treatment process is obtained throughout the following treatments:

- Oily slop from API/PPI system has totally recovered as refinery feed that is re-processed (e.g. Crude Distillation Unit inlet).
- Oily sludge from thickening treatment has totally recovered as waste in order to produce energy by off-site incineration facilities.

**None innovative technologies able to provide energy saving, sludge production minimization and reuse of treated wastewaters are implemented.**

Inflows and outflows that are generally present in the Environmental permits released to ENI refineries, are indicated in figure A3:

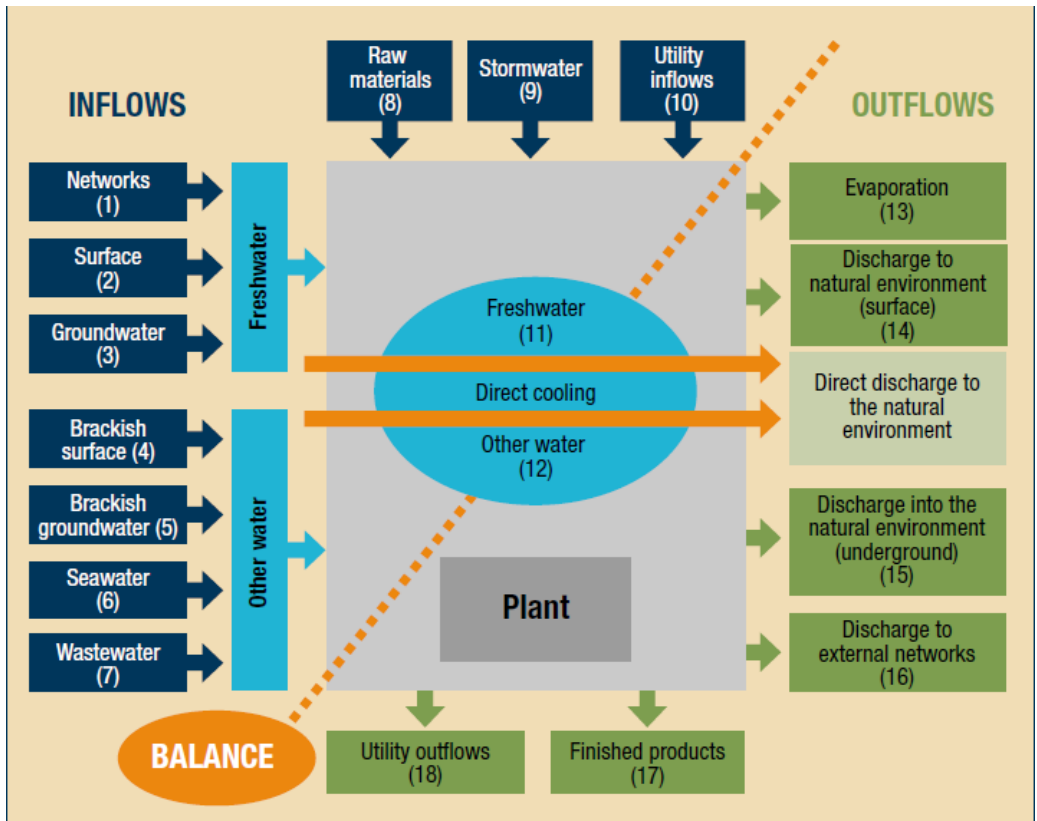

Fig. A3

## CASE STUDY B

### Water usage

In this kind of industry the average amount of water supplied is 6.180.000 m<sup>3</sup>/year of which the lower amount comes from the water piped network potable water (6 %) and the higher is equally distributed between groundwater (drilled wells/boreholes 47%) and surface water (47%). Water is mainly used for industrial purpose (97%) and only 3% for domestic use. The water losses account at 78%, while 5% is discharged once used.

Water treatment is required with any boiler or steam generator to protect against corrosion and scaling.

#### A. Raw water treatment for boiler feed or steam generator / technological steam generation

The water treatment process consist in: filtering for iron removal, water softening to remove calcium and magnesium, pre-heating and degasification for removal of dissolved oxygen to prevent corrosion, and additional demineralization with Clayton solution.

#### B. Raw water treatment for hot water boilers

This involves water softening on ion-exchange resins.

New approaches implemented for reducing fresh water consumption are:

- Oil Parks conversion into skids, thus no water use in the new facilities (electrical heating instead of steam heating);
- High-energy, high-water losses pumps replaced by automated pumps, highly performing, at water stations and at water injection stations;
- Old compressors with water-cooling replaced by new compressors with air cooling (or with glycol or hydraulic oil cooling);
- Increase use of desalinated sea water instead of freshwater from public supply, in offshore.

The measure adopted for minimizing water losses consist of:

- Repair of facilities with water or steam losses (e.g. hydrant systems, cooling towers at old compressor stations, water transportation pipelines, steam pipelines at power stations, steam heating lines at oil parks);
- Working points switched from public water network to own water wells, which resulted in reduced water consumption by avoiding water losses from old pipelines;
- Quarterly and Annual monitoring of water withdrawal (requirement of Water Strategy);
- Water Management Plans (requirement of company Water Strategy and Environmental Management Standard);
- Water reduction targets, water reporting – internal ("HSE Monitor") and external (e.g. to CDP Water, IOGP);

- Rising awareness events (requirement of company Water Strategy, HSSE Policy): water campaign, annual awards for best performance in water management.

### Wastewater treatment

This description refers to single-installation for produced water and wastewater treatment plant, with physical-chemical and biological treatment stages, with an innovative fourth purification stage on activated carbon.

- A. Physical chemical stage consists in coagulation, flocculation and flotation (Dissolved Air Flotation – DA)

Coagulants and flocculants, respectively, are mixed with the produced water stream for improving the separation process of suspended solids and hydrocarbons. The coagulant solution has an acid character. A neutralization facility was not needed, as the alkalinity in the influent is high enough to ensure buffer for the maximum dosing quantity of coagulant.

From the flocculation tank, the wastewater flows by gravity to the Dissolved Air Flotation (DAF) Units. In the DAF units the produced water is clarified. The separation process is enhanced by recirculation and dissolving of compressed air. The suspended solids and oil are accumulated as a scum at the top of the unit, collected and conveyed by gravity to the sludge buffer tank. The clarified produced water flows from each unit, by gravity, directly to the biological stage.

- B. Biological stage with activated sludge system for aerobic carbon and nitrogen removal

At this stage, carbon is further removed by specific adapted microorganisms working in aerated tanks with air diffuser system and optional nitrogen nutrient dosing for simultaneous nitrification denitrification. If not sufficient nutrients for biomass growth are available and in order to create the adequate living conditions for the biomass, it is possible to dose urea and phosphoric acid as nitrogen, respectively phosphorus source.

Clarification: After biological treatment, the mixed liquor of produced water and biomass flows by gravity to the downstream clarifiers. The settled sludge is collected by the bottom scrapper system and conveyed to the sludge pit constructed at the inlet of the clarifier. The collected sludge will be recirculated at the inlet of the biological stage, in the admission chamber, with a fixed flowrate. Part of the settled sludge is extracted from the biological system as excess sludge and pumped continuously upstream the coagulation tanks in order to be removed in the DAF units.

Dual media filtering: In order to minimize the pollution load to the downstream GAC filters, dual media filters are installed upstream of the GAC final treatment step. The operation is done with pressure which is created by an upstream intermediate pumping station. Before entering the filters, a low quantity of coagulant is added to the produced water for coagulation and hence for improving the separation rates during dual media filtration. While passing the filtration media, the suspended solids are removed and the produced water flows to the last treatment stage – the granulated activated carbon filtration.

- C. Granulated activated carbon filtration

The activated carbon adsorption has the goal to reduce the remaining COD and phenol to the required effluent limits. After passing the last treatment stage, the GAC filtered waste water is discharged to the river.

**Sludge treatment:** All the sludge streams collected in the produced water / wastewater treatment plant are thickened in the DAF unit, from where the sludge flows by gravity to the sludge buffer tank. This tank acts as a feed tank for the downstream dewatering facility (two phases centrifuge for liquid – solid separation). In order to enhance the separation in the centrifuge, polyelectrolyte is added to be mixed with the sludge. The separated solids (filter cake) are sent to a container, and then transported for disposal. The liquid phase (oil-water) flows to an API separator where a further separation of the remaining oil takes place. The water flows afterwards directly to the wastewater tank, while the oil phase is sent to the slop oil tank.

**In particular the fourth purification stage on activated carbon is an innovative technology in wastewater treatment and in terms of advanced wastewater purification.**

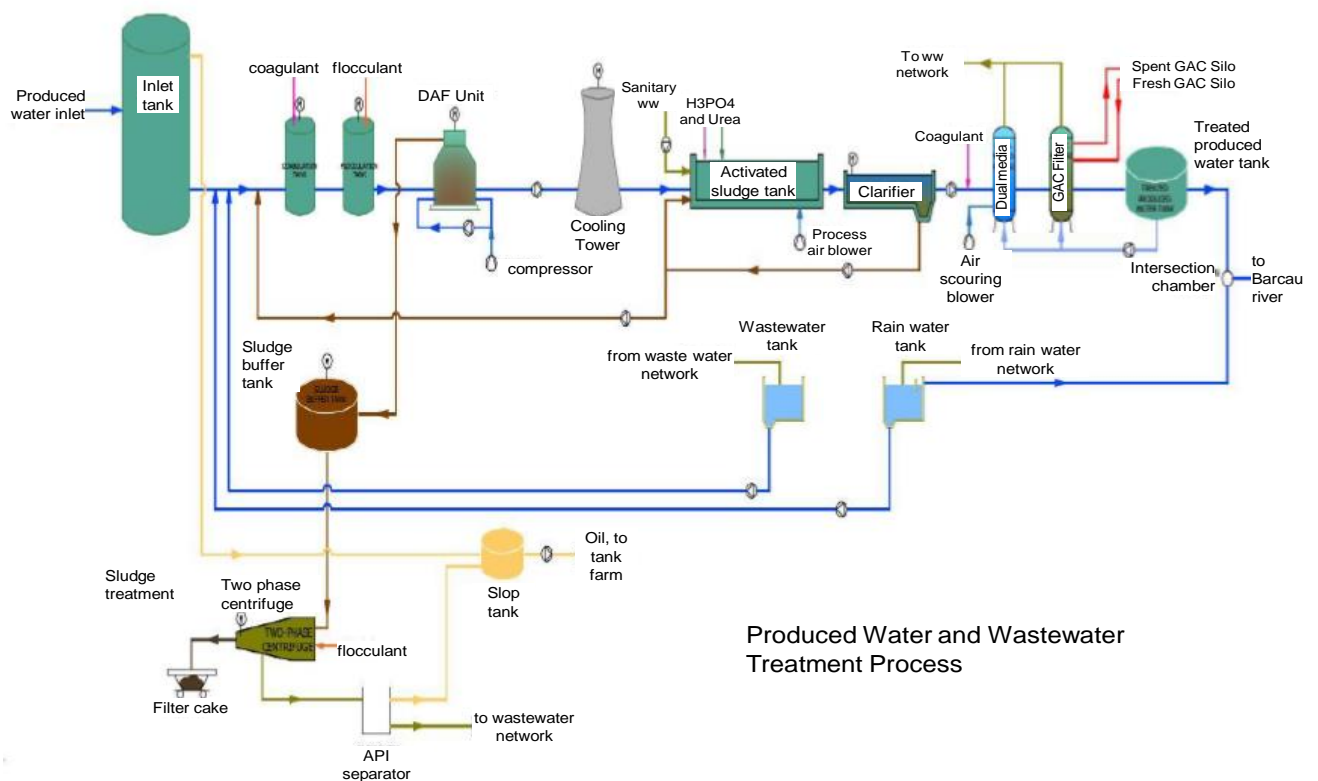

Fig. B1

## CASE STUDY C

### Water usage

In this kind of industry the average amount of water supplied is 6.400.000 m<sup>3</sup>/year of which the higher amount comes from the water piped network non-potable water (99 %) and mainly from surface water (99%). Water is used for industrial purpose (99%) and only 1% for domestic use. The water discharged once used is about 60%.

New approaches implemented for reducing fresh water consumption are:

- Reuse of rainwater in the fire network, minimizing the consumption of raw water for fire training and response to emergencies;
- Reuse of process water from the amine units, to be used in desalters, that consequently reduces the consumption of raw water in this unit.

### Water reuse

The total water reused/recycled in 2016 is 7,4x10<sup>5</sup> m<sup>3</sup>. The partial reuse in the same industry is about 100%. Improvements for water reuse have been made (e.g. at procedure level), however these improvements cannot be considered as processes/technologies.

### Wastewater treatment

Wastewater pre-treatment occurs at the site before it is send to an external facility for treatment and discharge.

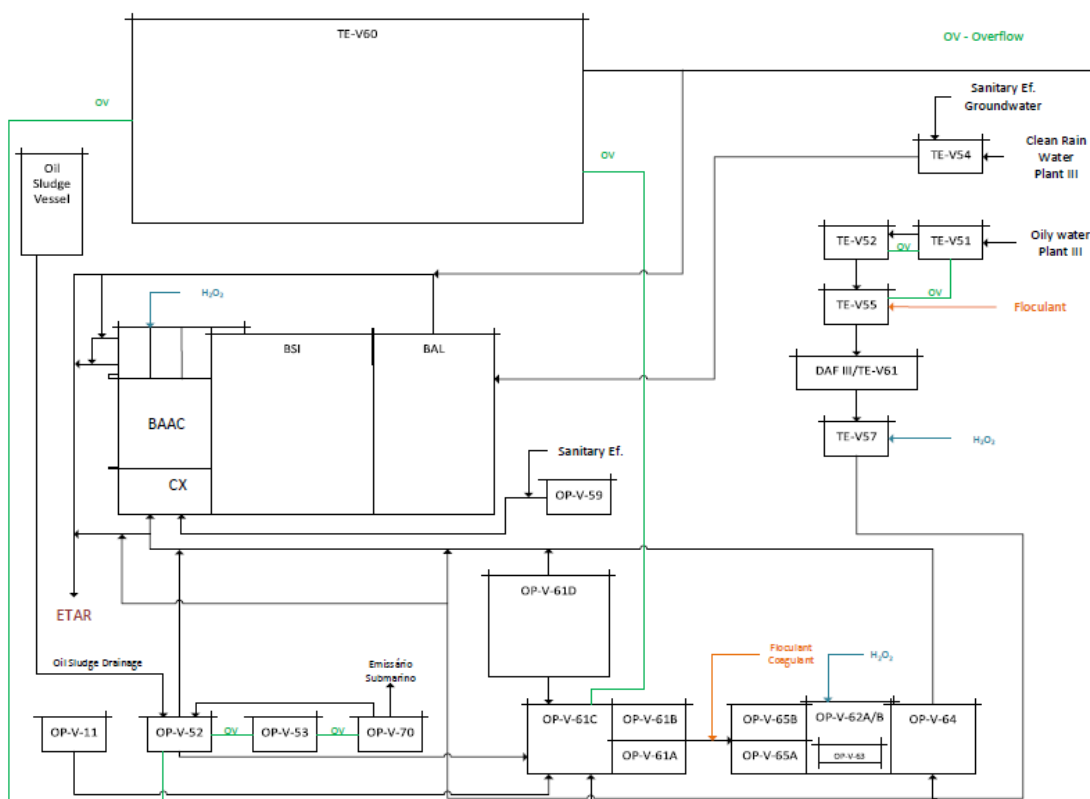

Fig. C1



The company has to comply with external entity regulation (entity that receives and treats the wastewater). This regulation sets discharge values for certain pollutants. The company is taxed based on these values according to their wastewater quality.

The type of wastewater treatment consists of only pre-treatment: Oil-water separation; Flotation and oxidation.

**None innovative technologies able to provide energy saving, sludge production minimization and reuse of treated wastewaters are implemented.**

## PULP&PAPER SECTOR

### CASE STUDY D

#### Water usage

In this kind of industry the average amount of water supplied is 66.059.000 m<sup>3</sup>/year (2015 data) of which the higher amount comes from surface water (66%). Water is totally used for industrial purpose (100%). The raw water treatment process consists of:

- Decantation; Filtration, pH correction;
- Oxidation treatment – chlorination;
- Preparation and dilution of process chemicals;
- Consistency correction;
- Fiber washing.

The measure adopted for minimizing water losses are the following:

- Optimization of the use of the water resource - Closing of the circuits (ex: bleaching, evaporation, among others ...);
- Reuse of secondary waters for less demanding process steps;
- Increased recovery of live steam condensates;
- Modified cooking before bleaching;
- High efficiency debarking and washing systems on wood preparation stage; cleaning and closed-circuit screening;
- Partial Recirculation of process water through bleaching stages;
- Effective spill monitoring and containment including recovery of substances and energy;
- Separation, for reuse, of the less contaminated water used in the sealing of vacuum pumps;
- Separation, for reuse, of the cooling water of contaminated water from the process;
- Reuse of process water in substitution of raw water for recirculation and closure of water circuits;
- In-line (partial) treatment of process water to improve its quality to allow recirculation or reuse.

#### Wastewater treatment

The wastewater treatment consists of sand/oil interceptor, equalization, acid neutralization and solids interceptor. **None innovative technologies able to provide energy saving, sludge production minimization and reuse of treated wastewaters are implemented.**

## **CASE STUDY E**

### Water usage

In this kind of industry there are no leaks in surface water. The sewerage system and semi-buried concrete basins in the treatment plants may have losses in soil and underground water only in accidental situations. The company has a program of maintenance, repair and rehabilitation of all sewerage circuits, including storm sewers.

The discharged water is about 97% of the water consumption (surface and underground).

For the production of industrial process water and softened water required for the manufacturing process, raw water taken from the river is treated differently for its use for technological purposes and for the heating plant.

The raw water is introduced into two slurry decanters, with a settling time of 2.5 hours. Technological / industrial water is thus obtained.

In order to obtain softened water at the thermal power plant (CTAT and CAD), the company owns a modern, automatic re-alkalinisation plant with softening and chemical conditioning.

For wastewater technology, the following categories of measures and techniques for preventing and minimizing emissions to water are applied:

- Measures / techniques BATC - PPI 2014 general and specific for the manufacture of recycled / scrap paper, namely BAT1, BAT2, BAT 42, BAT 5, BAT 43, BAT 44, BAT 10, BAT 13, BAT 14, BAT 15, BAT 16;
- Measures / techniques of internal pre-treatment within technological processes;
- Sewage treatment techniques in the treatment plant provided with physicochemical and biological treatment steps.

### Water reuse

1. Flotation and water recirculating plant at the paper machine for the manufacture of corrugated cardboard

In order to reduce the loss of fibrous material in the corrugated paper machine and to reduce the consumption of fresh water, the fatty water from the process is recycled to the paper machine and the maculation preparation plant, and the excess water in the secondary circuit is sent to the existing flotation system with dissolved air - DAF.

2. Internal circuit on the toilet paper machine The fatty streams resulting from the dehydration steps of the paper pulp are used in the phases where dilutions are required and at the maculation preparation plant.

### Wastewater treatment

The waste water resulting from the company's activity is collected through internal sewerage systems in each installation and then taken over by the sewage system (technological, domestic, rainwater) and directed to the sewage treatment plant. The company has a wastewater treatment

plant that currently operates at a capacity of approx. 150 l/s and having components built and dimensioned adaptable according to the characteristics of the wastewater to be treated. The treatment plant consists of the following steps:

A. Waste water treatment plant:

Mechanical cleaning - removing coarse suspensions

Physical-chemical scrubbing with the phases:

- dosing of flocculation agents; - sedimentation - removal of sludge

Biological purification with the following phases:

- aeration - nutrient dosing - rinse - recirculating sludge

B. Sewage treatment plant

It consists of 17 reservoirs (2 storage tanks, 3 denitrification tanks, 9 aeration tanks, 3 denitrification tanks) and 5 submersible pumps with grille and flow distributor, aeration system with air diffusers and air timing ( 4 pieces). Purified waters unite in the collector basin and are then discharged into the river.

The mixture of primary and biological sludge in excess from the sewage treatment plant is deposited in two storage-discharge towers, where sludge settling occurs, increasing its consistency from approx. 6-8% at ca.9-13%. To achieve optimal settling time, the two storage towers are used intermittently. In order to optimize the settling process, flocculant (polyacrylamide) is dosed on the feeding pipes of the two towers. After chemical treatment with coagulant and flocculant, the sludge mixture is sent to the dewatering, drying and co-incineration plant.

Corrugated Cardboard Filling Machine:

- Waste water technology with flocculent and coagulant
- Clear water is used in the paper pulp preparation plant
- The sludge is discharged into the technological wastewater circuit of the machine, then going through the physicochemical and biological treatment stages of the treatment plant, finally being recovered in the excessively large primary and biological sludge from the treatment plant.

**None innovative technologies able to provide energy saving, sludge production minimization and reuse of treated wastewaters are implemented.**

Even if the treated wastewater is reused, the amount of sludge increases, does not decrease.

Sludge, due to its large quantities, is a problem in the pulp and paper industry.

## CASE STUDY F

### Water usage

In this kind of industry the average amount of water supplied is 196.000.000 m<sup>3</sup>/year of which the higher amount comes from the water piped network potable water and equally distributed between groundwater (48%) and surface water (52%). Water is used for industrial purpose (100%), the water losses account at 7% for process evaporation during paper drying. The water discharged once used is about 93%.

Inlet water is treated, depending on water quality, by grate and filters to remove large object and small particles. In few cases raw inlet water could also be disinfected.

Water is the main “carrier” of the papermaking process. Water consumption minimization is at the centre of the attention. There is not a new approach but a continuous fine tuning. Main limitation to water consumption minimization is the Italian legislation itself as it is based on concentration of pollutants in discharged water.

Water losses in papermaking is the unavoidable evaporation during paper drying. For energy saving needs, energy is recovered as much as possible and low temperature vapour is emitted. This vapour, due to the large quantity is not condensated.

### Water reuse

There are two main technology for treating water for reuse (flotation and biological treatment) but in papermaking there are many different ways and places to reuse it. There are two or three main water loops (white water circuits) and many different places where water is reused (as stock preparation, chemicals dilution, etc.). Fresh water is directly used only where it is strictly necessary.

In this way the partial reuse in the same industry is about 90 %.

Water is so relevant for their process that each and any paper mill periodically makes its own analysis of the water circuits and optimization to reduce water consumption and to guarantee paper quality.

### Wastewater treatment

- 100% of paper mills have a primary (chemical-physical) waste water treatment plant.
- 68% of paper mills have a secondary (aerobic or anaerobic) waste water treatment plant.
- 24% of paper mills have a tertiary (filtration, ozone, etc.) waste water treatment plant
- 18% of paper mills send waste water to an external waste water treatment plant.

Chemical-physical sludges and biological sludge are used for land reclamation and agriculture (33%), brick and cement industry (8%), other paper mills (8%), other industries (3%).

Sludges are pressed to remove water before reuse in other processes or sent to landfill. In few cases paper mill are able to reuse their own sludges. In this case sludges are reused directly without any treatment.

**None innovative technologies able to provide energy saving, sludge production minimization and reuse of treated wastewaters are implemented.**

However the level of re-use of treated water is already very high (>90%). Water use could not be further reduced without increasing concentration of waste water pollutants.

Discharge mainly occurs in their own WWTP with natural outlet (82%) and in centralized WWTP or urban WWTP with natural outlet (18 %).